

EXP-40V

REVISION: -
ECO NO: -
BY: J. KUSBEL
DATE: 2/07/2012

COXREELS SERIES V-117

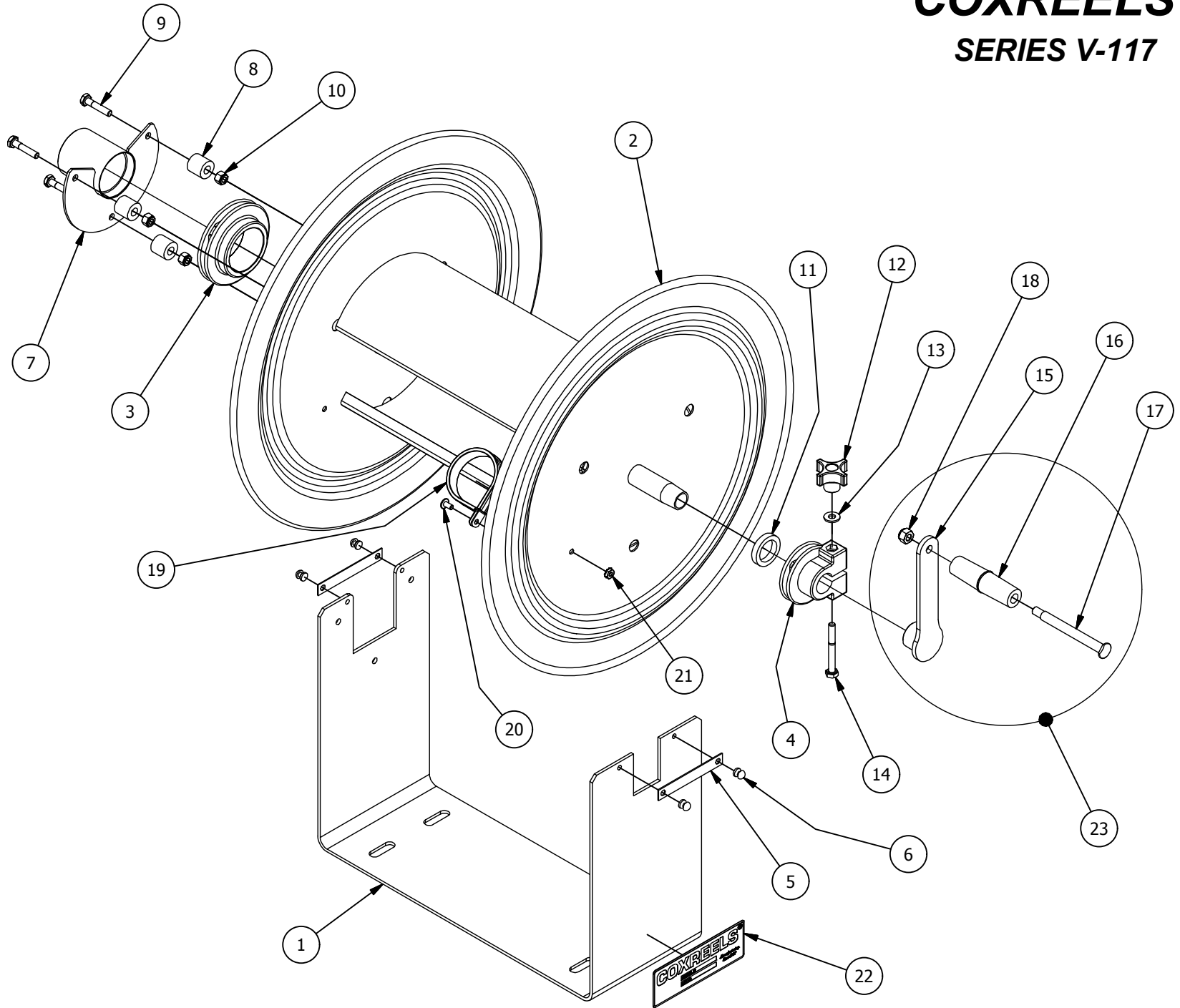

EXP-40V

COMMON PARTS TO VACUUM CHALLENGER REELS

ASSY. ITEM NO.	DETAIL ITEM NO.	PART NO.	DESCRIPTION	V-117-850
	1	8804-13.5	FRAME, "U", CHALLENGER	1	-
				-	-
	2	8810-13.5	DRUM ASSEMBLY	1	-
				-	-
	3	8552-1	BEARING, EPDM, 1.875" ID	1	-
	4	6329-1-1	BEARING, EPDM, .877" ID, CRANK SIDE	1	-
	5	15711-1	PLATE, KEEPER, BEARING	2	-
	6	7105	RIVET, POP, 3/16	4	-
	7	8806	FLANGE, HOSE	1	-
	8	16017-1	SPACER, DELRIN, 0.72" LG	3	-
	9	141	BOLT, HEX, 1/4-20 X 1-1/4"	3	-
	10	3859	NUT, LOCK, 1/4-20	3	-
	11	7145	SPACER, PVC, 0.25"	1	-
	12	15719	KNOB, BLACK, PHENOLIC	1	-
13	688	WASHER, FLAT, 1/4"	1	-	
14	7146	BOLT, HEX, 1/4-20 X 2-1/4"	1	-	
23		7272-1	HAND CRANK ASSEMBLY	1	-
	15	7107	ARM, CRANK, 100 SERIES	1*	-
	16	6333	HANDLE, CRANK, PLASTIC	1*	-
	17	1621	BOLT, SHOULDER, 5/16-18	1*	-
	18	111	NUT, LOCK, 5/16-18	1*	-
	19	399	CLAMP, HOSE, #32	1	-
	20	245	SCREW, TRUSS HD, 10-32 X 3/8"	1	-
	21	130	NUT, KEPS, 10-32	1	-
	22	10925-5	NAMEPLATE, PRODUCT, STD DECAL	1	-

* SHOWN FOR REFERENCE. INCLUDED WITH HAND CRANK ASSEMBLY.

REVISION: -

ECO: -

DATE: 02/07/12

NAME: J. KUSBEL