

LED Hybrid PL Vertical

PLEASE REVIEW THE INSTRUCTIONS AND WARNINGS LISTED BELOW PRIOR TO PROPER INSTALLATION

Thank you for selecting LED type(A+B) PL Lamp. Please install and use the product according to the instructions below to ensure the correct installation and function of our LED product. Failure to follow these instructions will void your warranty. We take no responsibility for inappropriate use and/or installation of the product, and any associated damage caused by such actions.

Type A+B LED PL retrofit lamps can be used as a replacement for (4-pin) compact fluorescent bulbs (CFLs) and are compatible with both electrical ballasts and 120-277V line voltage. Installation can be direct plug-and-play with a working and compatible ballast (list below), or the ballast can be bypassed in the case of a failing or incompatible ballast.

Universal G24 and GX24 4-pin base retrofits G24Q-1, G24Q-2, G24Q-3, GX24Q-1, GX24Q-2, and GX24Q-3.

WARNINGS

- Risk of fire or electric shock. LED Retrofit Kit installation requires knowledge of luminaires' electrical systems. If not qualified, do not attempt installation. Contact a qualified electrician.
- Risk of fire or electric shock. Install this kit only in luminaires that have the construction features and dimensions shown in the photographs and/or drawings and where the input rating of the retrofit kit does not exceed the input rating of the luminaire.
- To prevent wiring damage or abrasion, do not expose wiring to edges of sheet metal or other sharp objects.
- Risk of fire or electric shock. Do not alter, relocate, or remove the wiring, lamp holders, power supply, or any other electrical component.

CAUTIONS

- **CAUTION RISK OF FIRE** - If the lamp or luminaire exhibits undesirable operation(buzzing, flickering, etc.), Immediately turn off the power, remove the lamp from luminaire and contact manufacturer.
- The products were intended to retrofit surface mount, Type IC or non-IC recessed mount Listed fluorescent luminaires. Horizontal version PL lamp that uses a maximum of two lamps, with the two lamps spaced 1 mm minimum apart. The minimum lamp compartment dimensions are 155*140 mm. Vertical version PL that uses only one lamp, and the lamp compartment dimensions are 145*180mm.
- LED retrofit luminaire conversion for use only with products described and installed in accordance with the instructions provided with this retrofit kit.
- Installers should not disconnect existing wires from lamp holder terminals to make new connections at lamp holder terminals. Instead, installers should cut the existing lamp holder leads away from the lamp holder and make new electrical connections to lamp holder lead wires by employing applicable connectors.
- Do not make or alter any open holes in an enclosure of wiring or electrical components during kit installation.
- This retrofit kit is accepted as a component of a luminaire where the suitability of the combination shall be determined by authorities having jurisdiction.
- The retrofit assembly is accepted as a component of a luminaire where the suitability of the combination shall be determined.
- Not for use with dimmers. This device is not intended for use with emergency exits.

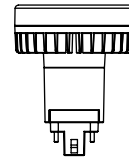

LED Hybrid PL

Vertical

PLEASE REVIEW THE INSTRUCTIONS AND WARNINGS LISTED BELOW PRIOR TO PROPER INSTALLATION

BYPASS BALLAST (RECOMMENDED)

1. Make sure the circuit breaker that supplies power to the fixture is turned off.
2. Remove trim and existing lamp(s) from a recessed fixture. Drop housing from the plaster frame.
3. Remove inner junction box cover and disconnect ballast from input wiring and lamp holder leads. Dispose of removed ballast and lamps in accordance with government regulations in your area.
4. Connect input wiring to the lamp holder leads according to the appropriate diagram below. Place wires and connections back in the wiring box and replace the cover.
5. Reinstall housing and trim.
6. Install your new LED Hybrid PL lamps. Rotate lamps to the desired position.
7. Apply relamping Label on a visible location inside the fixture.
(THIS LUMINAIRE HAS BEEN MODIFIED TO OPERATE LED LAMPS. DO NOT ATTEMPT TO INSTALL OR OPERATE FLUORESCENT LAMPS IN THIS LUMINAIRE.)
8. Turn power on at the breaker box and turn on the lights.

INSTALLATION INTRODUCTIONS

Figure 1: Retrofit with One Lamp (G24Q Base)

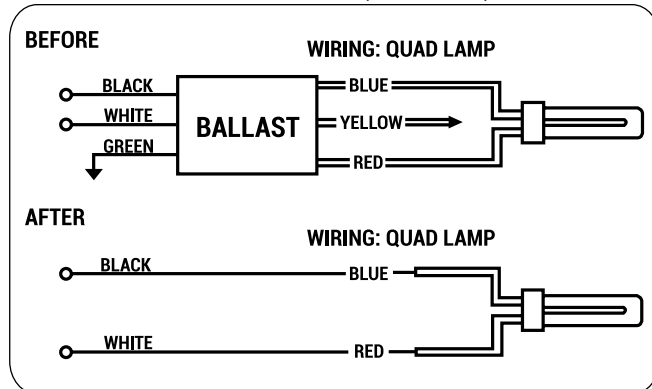
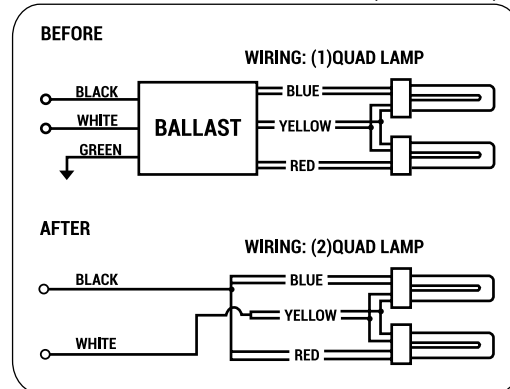
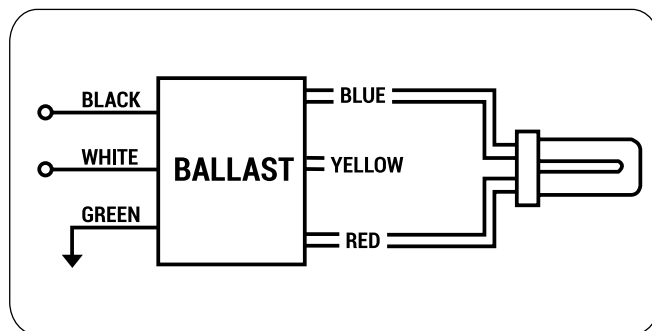

Figure 2: Retrofit with Two Lamps (G24Q Base)



Direct plug and play with ballast



Note: If you choose Plug and Play installation method, please this lamp only operates in electronic ballasts. If the lamp does not light when the luminaire is energized, remove the lamp from luminaire and contact lamp manufacturer or a qualified electrician.