



HIRSCHMANN

A **BELDEN** BRAND

User Manual

Installation

Industrial ETHERNET Rail Switch

RS20/RS22/RS30/RS32/RS40 Family

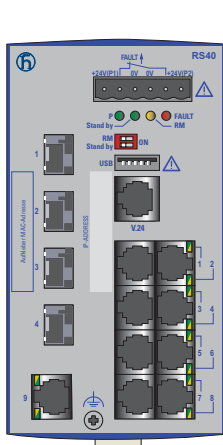

RS40-0009...

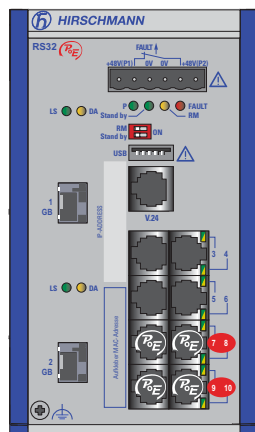

RS32-0802...

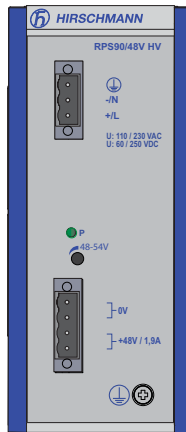

RPS90/48V HV

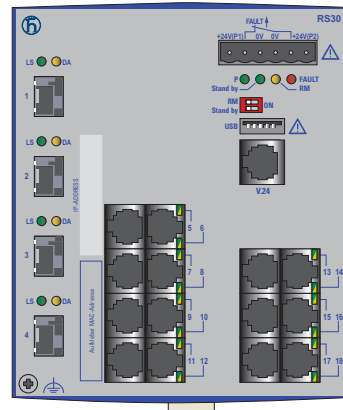

RS30-1602...

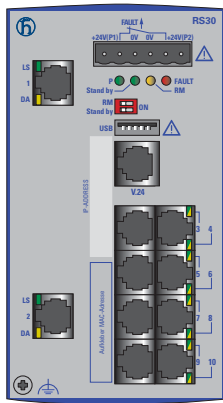

RS30-0802...

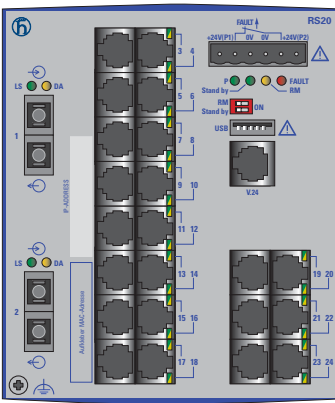

RS20-2400...

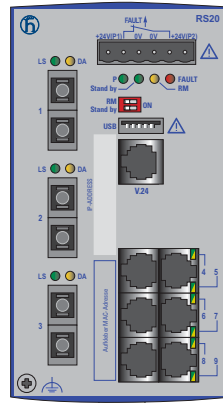

RS20-0900...

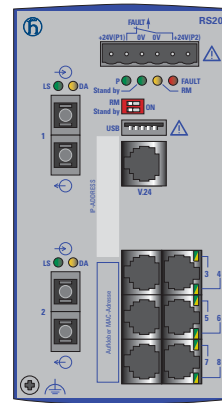

RS20-0800...

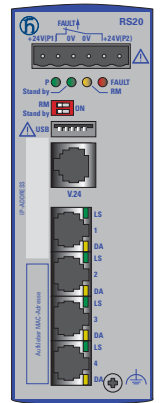

RS20-0400...

The naming of copyrighted trademarks in this manual, even when not specially indicated, should not be taken to mean that these names may be considered as free in the sense of the trademark and tradename protection law and hence that they may be freely used by anyone.

© 2016 Hirschmann Automation and Control GmbH

Manuals and software are protected by copyright. All rights reserved. The copying, reproduction, translation, conversion into any electronic medium or machine scannable form is not permitted, either in whole or in part. An exception is the preparation of a backup copy of the software for your own use.

The performance features described here are binding only if they have been expressly agreed when the contract was made. This document was produced by Hirschmann Automation and Control GmbH according to the best of the company's knowledge. Hirschmann reserves the right to change the contents of this document without prior notice. Hirschmann can give no guarantee in respect of the correctness or accuracy of the information in this document.

Hirschmann can accept no responsibility for damages, resulting from the use of the network components or the associated operating software. In addition, we refer to the conditions of use specified in the license contract.

You can get the latest version of this manual on the Internet at the Hirschmann product site (www.hirschmann.com).

Hirschmann Automation and Control GmbH
Stuttgarter Str. 45-51
72654 Neckartenzlingen
Germany
Tel.: +49 1805 141538

Contents

Safety instructions	5
About this Manual	18
Key	18
1 Description	19
1.1 Description of the device variants	21
1.1.1 Combination options of the device variants RS20/RS30/RS22/RS32	23
1.1.2 Combination options for the RS40 device variants	26
1.1.3 Number of ports and media for RS20-...	27
1.1.4 Number of ports and media for RS30-...	30
1.1.5 Number of ports and media for RS40-...	33
1.2 Device variants with PoE (optional)	34
1.2.1 Number of ports and media for devices with PoE	34
1.2.2 PoE power units	36
1.3 Ethernet ports	37
1.3.1 10/100/1000 Mbit/s twisted pair port	37
1.3.2 10/100 Mbit/s twisted pair port	38
1.3.3 10/100 Mbit/s twisted-pair connection PoE (RS22-.../RS32-...)	38
1.3.4 1000 Mbit/s F/O port	39
1.3.5 100 Mbit/s F/O port	40
1.3.6 Gigabit combo port	40
1.4 Display elements	42
1.5 Management interfaces	44
1.5.1 USB interface	44
1.5.2 V.24 interface (external management)	44
2 Installation	45
2.1 Checking the package contents	46
2.2 Installing and grounding the device	46
2.2.1 Installing the device onto the DIN rail	47
2.2.2 DIN rail mounting on ships (RS30-0802...)	48
2.2.3 Mounting on a vertical flat surface	48
2.2.4 Grounding the device	49
2.3 Installing an SFP transceiver (optional)	50
2.4 Adjust DIP switch settings	50

2.5	Connecting the terminal block	51
2.5.1	RS20/RS30/RS40: supply voltage and signal contact	51
2.5.2	RS22/RS32: supply voltage and signal contact	53
2.6	Mounting the terminal block	56
2.7	Connecting the ferrite	56
2.8	Operating the device	57
2.9	Connecting data cables	57
2.10	Filling out the inscription label	58
3	Making basic settings	59
4	Monitoring the ambient air temperature	60
5	Maintenance and service	61
6	Disassembly	62
6.1	Removing the device	62
6.2	Removing an SFP transceiver (optional)	63
7	Technical data	64
A	Further Support	79

Safety instructions

WARNING

UNCONTROLLED MACHINE ACTIONS

To avoid uncontrolled machine actions caused by data loss, configure all the data transmission devices individually.

Before you start any machine which is controlled via data transmission, be sure to complete the configuration of all data transmission devices.

Failure to follow these instructions can result in death, serious injury, or equipment damage.

■ **General safety instructions**

You operate this device with electricity. Improper usage of the device entails the risk of physical injury or significant property damage. The proper and safe operation of this device depends on proper handling during transportation, proper storage and installation, and careful operation and maintenance procedures.

- Before connecting any cable, read this document, and the safety instructions and warnings.
- Operate the device with undamaged components exclusively.
- The device is free of any service components. In case of a damaged or malfunctioning the device, turn off the supply voltage and return the device to Hirschmann for inspection.

■ **Certified usage**

Use the device solely for the application cases described in the Hirschmann product information, including this manual.

Operate the device solely according to the technical specifications.

See [“Technical data” on page 64](#).

■ Installation site requirements

- Install the device in a fire enclosure according to EN 60950-1.
- If installed in a living area or office environment, the device must be operated only in switch cabinets with fire protection characteristics according to EN 60950-1.

Only when using the PoE power supply unit RPS90/48V HV:

- Install the device at ambient temperatures greater than 113 °F (45 °C) in “restricted access locations” based on EN 60950-1 exclusively.
Install this device solely in a switch cabinet or in an operating site with restricted access, to which maintenance staff have exclusive access.

■ Device casing

Only technicians authorized by the manufacturer are permitted to open the housing.

- Never insert pointed objects (narrow screwdrivers, wires, etc.) into the device or into the connection terminals for electric conductors. Do not touch the connection terminals.
- Keep the ventilation slits free to ensure good air circulation.
[See “General technical data” on page 64.](#)
- Install the device in the vertical position.
- At ambient temperatures > 140 °F (60 °C):
The surfaces of the device housing may become hot. Avoid touching the device while it is operating.

■ Qualification requirements for personnel

- Only allow qualified personnel to work on the device.

Qualified personnel have the following characteristics:

- ▶ Qualified personnel are properly trained. Training as well as practical knowledge and experience make up their qualifications. This is the prerequisite for grounding and labeling circuits, devices, and systems in accordance with current standards in safety technology.
- ▶ Qualified personnel are aware of the dangers that exist in their work.
- ▶ Qualified personnel are familiar with appropriate measures against these hazards in order to reduce the risk for themselves and others.
- ▶ Qualified personnel receive training on a regular basis.

■ National and international safety regulations

Verify that the electrical installation meets locally or nationally applicable safety regulations.

■ **Grounding the device**

The housing is grounded via the separate ground screw on the bottom left of the front panel.

- Use a wire diameter for the ground conductor that is no smaller than the diameter of the supply voltage connection, however of at least 1.0 mm² (AWG16).
- Ground the device before connecting any other cables.
- Disconnect the grounding only after disconnecting all other cables.

■ **Shielding ground**

The overall shield of a connected shielded twisted pair cable is connected to the ground connector on the front panel as a conductor.

- Beware of possible short circuits when connecting a cable section with conductive shielding braiding.

■ Supply voltage

The supply voltage is electrically isolated from the housing.

- The devices are designed for operation with safety extra-low voltage. Connect only SELV circuits with voltage restrictions in line with IEC/EN 60950-1 to the supply voltage connections and signal contacts.
- Connect only a supply voltage that corresponds to the type plate of your device.
- Observe the maximum values for the contact load of the signal contact.
- Relevant for North America:
The device may only be connected to a Class 2 supply voltage that fulfills the requirements of the National Electrical Code, Table 11(b). If the voltage is being supplied redundantly (two different voltage sources), the combined supply voltages must fulfill the requirements of the National Electrical Code, Table 11(b).
- Relevant for North America: For use in class 2 circuits.
Use 60/75 °C (140/167 °F) or 75 °C (167 °F) copper (Cu) wire only.
- Relevant for North America
for devices certified for hazardous locations:
Power, input and output (I/O) wiring must be in accordance with Class 1, Division 2 wiring methods [Article 501-4(b) of the National Electrical Code, NFPA 70] and in accordance with the authority having jurisdiction.

Start connecting the electrical wires only if **all** the above safety requirements are fulfilled.

- Enable the supply voltage for the device only when the following requirements are fulfilled:
 - ▶ the housing is closed
 - ▶ the terminal blocks are wired correctly
 - ▶ the terminal blocks for the power supply are connected
- Internal fuses are triggered only in the case of a detected error in the device. In case of damage or malfunction of the device, turn off the supply voltage and return the device to the plant for inspection.

■ **Supply voltage for PoE power supply units (optional)**

- Connect the protective conductor with the ground screw before you set up the other connections. When removing the cables, remove the protective conductor last.
 - Make sure that the cross-section of the protective conductor cable is the same size as or bigger than the cross-section of the voltage supply cables.
 - Only use connection cables that are permitted for the specified temperature range.
 - Connect only a supply voltage that corresponds to the type plate of your device.
 - ▶ PoE power supply unit RPS90/48V LV: 18 V DC to 60 V DC
 - ▶ PoE power supply unit RPS90/48V HV: 48 V DC to 320 V DC or 90 V AC to 265 V AC
 - Install a suitable input fuse in the following cases:
 - ▶ The neutral conductor or the negative terminal of the supply voltage is ungrounded.
 - ▶ For the supply voltage, you provide a DC voltage greater than 125 V DC.
- [See “General technical data” on page 64.](#)
- With AC power supply, use a cable cross-section of at least 0.75 mm² (for North America AWG 18) for the current conductor at the voltage input.
 - With DC power supply, use a cable cross-section of at least 1.0 mm² (for North America AWG 16) for the current conductor at the voltage input.

■ **ATEX directive 2014/34/EU – specific regulations for safe operation**

Relevant for RS20/22/30/32/40 devices when operating in explosive gas atmospheres according to ATEX Directive 2014/34/EU, the following applies:

- List of standards:
 - EN 60079-0:2012 + A11:2013
 - EN 60079-15:2010
 - Certificate No.: DEKRA 11ATEX0139 X or KEMA 09ATEX0067 X.

- Make sure that the device has the following label:

 **II 3G Ex nA IIC T4 Gc** **DEKRA 11ATEX0139 X**
for RS20/22/30/32 types.

 **II 3G Ex nA IIC T3 ... T4 Gc** **KEMA 09ATEX0067 X**
for RS40 types.

Ambient rating and temperature code for RS20 and RS30 types:

T4: $0\text{ °C} \leq T_a \leq +60\text{ °C}$ for “S” types

(item 14 of nomenclature breakdown) or

T4: $-40\text{ °C} \leq T_a \leq +70\text{ °C}$ for “T” or “E” types

(item 14 of nomenclature breakdown).

Ambient rating and temperature code for RS22 and RS32 types:

T4: $-40\text{ °C} \leq T_a \leq +50\text{ °C}$ for “T” or “E” types

(item 14 of nomenclature breakdown) or

T4: $0\text{ °C} \leq T_a \leq +50\text{ °C}$ for “S” types

(item 14 of nomenclature breakdown)

Ambient rating and temperature code for RS40 types:

T3: $-40\text{ °C} \leq T_a \leq +70\text{ °C}$ for “T” or “E” types

(item 14 of nomenclature breakdown).

T4: $-40\text{ °C} \leq T_a \leq +60\text{ °C}$ for “T” or “E” types

(item 14 of nomenclature breakdown).

T4: $0\text{ °C} \leq T_a \leq +60\text{ °C}$ for “S” types

(item 14 of nomenclature breakdown).

- The modules shall be installed in a suitable enclosure in accordance with EN 60079-15 providing a degree of protection of at least IP54 according to EN 60529, taking into account the environmental conditions under which the equipment will be used.
- When the temperature under rated conditions exceeds 70 °C at the cable or conduit entry point, or 80 °C at the branching point of the conductors, the temperature specification of the selected cable and cable entries shall be in compliance with the actual measured temperature values.

- Provisions shall be made to prevent the rated voltage from being exceeded by transient disturbances of more than 119 V.
- Connectors shall be connected or disconnected exclusively in dead-voltage state.
- DIP switches shall be switched exclusively in dead-voltage state.



The USB port shall remain disconnected.

■ **Relevant for use in explosion hazard areas (Hazardous Locations, Class I, Division 2):**

Relevant for North America for devices certified for Hazardous Locations: Power, input and output (I/O) wiring must be in accordance with Class I, Division 2 wiring methods [Article 501-4(b) of the National Electrical Code, NFPA 70] and in accordance with the authority having jurisdiction.

SUITABLE FOR USE IN CLASS I, DIVISION 2, GROUPS A, B, C AND D HAZARDOUS LOCATIONS, OR NON-HAZARDOUS LOCATIONS ONLY.

WARNING – EXPLOSION HAZARD – SUBSTITUTION OF ANY COMPONENTS MAY IMPAIR SUITABLE FOR CLASS I, DIVISION 2.

WARNING – EXPLOSION HAZARD – DO NOT DISCONNECT EQUIPMENT WHILE THE CIRCUIT IS LIVE OR UNLESS THE AREA IS KNOWN TO BE FREE OF IGNITABLE CONCENTRATIONS.

The USB connector is for temporary connection only. Do not use, connect, or disconnect unless area is known to be non-hazardous. Connection or disconnection in an explosive atmosphere could result in an explosion.

Peripheral equipment must be suitable for the location it is used in. Use 60/75 °C (140/167 °F) or 75 °C (167 °F) copper (Cu) wire only.

Avertissement - Risque d'explosion - Ne pas débrancher tant que le circuit est sous tension à moins que l'emplacement soit connu pour ne contenir aucune concentration de gaz inflammable.

Avertissement - Risque d'explosion - La substitution de tout composant peut rendre ce matériel incompatible pour une utilisation en classe I, division 2.

CONTROL DRAWING: Hazardous Locations Class I, Division 2, Groups A, B, C, D

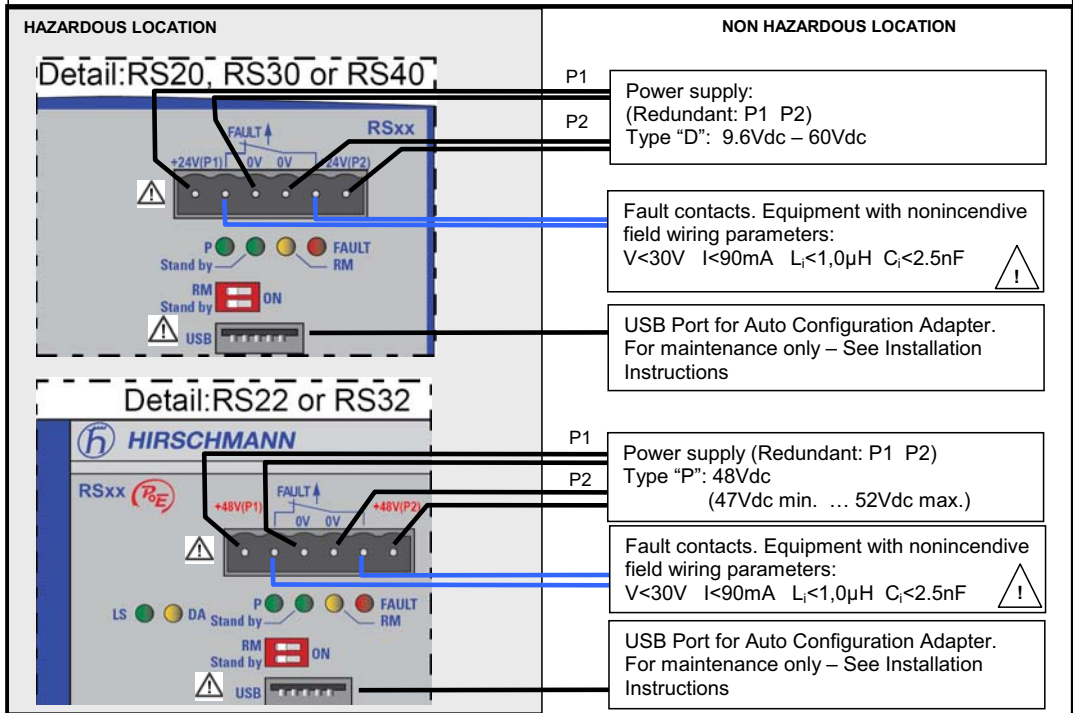

Notes:

The nonincendive field wiring circuit concept allows interconnection of nonincendive field wiring apparatus and associated nonincendive field wiring apparatus using any of the wiring methods permitted for unclassified locations when certain parametric conditions are met.

$C_a \geq C_i + C_{Cable}$; $L_a \geq L_i + L_{Cable}$

Nonincendive field wiring circuits must be wired in accordance with the National Electrical Code (NEC), NFPA 70 , article 501.

Nonincendive Field Wiring Parameters:

Entity Parameters ... for Class I, Division 2, Groups A,B,C,D =>	V_{max} [V]	I_{max} [mA]	C_i [nF]	L_i [μH]
Fault contacts	30	90	2.5	1.0



WARNING - EXPLOSION HAZARD – SUBSTITUTION OF ANY COMPONENTS MAY IMPAIR SUITABILITY FOR HAZARDOUS LOCATIONS OR EXPLOSIVE ATMOSPHERES.

WARNING - EXPLOSION HAZARD - DO NOT DISCONNECT EQUIPMENT UNLESS POWER HAS BEEN SWITCHED OFF OR THE AREA IS KNOWN TO BE NON-HAZARDOUS.

DO NOT OPEN WHEN ENERGIZED.



CONTROL DRAWING for RS20, RS22, RS30, RS32 and RS40 Family

Size A4	Document No.: 000157671DNR	Rev. 0
Date: 2011-09-21	Sheet 1 of 1	

■ IECEx – Certification Scheme for Explosive Atmospheres



For RS20/22/30/32/40 devices labeled with an IECEx certificate number, the following applies:

- List of standards:
 - IEC 60079-0:2011+ Corr. 2012 + Corr. 2013
 - IEC 60079-15:2010
- The device is suitable for use in an area with a degree of soiling of 2 as per IEC 60664-1

- Make sure that the device has the following label:

 **Ex nA IIC T4 Gc** **IECEx DEK 14.0077X**
for RS20/22/30/32 types.

 **Ex nA IIC T3 ... T4 Gc** **IECEx DEK 14.0076X**
for RS40 types.

Environmental class and temperature code for types RS20 and RS30:

T4: $0\text{ °C} \leq T_a \leq +60\text{ °C}$ for "S" types

(Item 14 in the schematic legend) or

T4: $-40\text{ °C} \leq T_a \leq +70\text{ °C}$ for "T" or "E" types

(Item 14 in the schematic legend).

Environmental class and temperature code for types RS22 and RS32:

T4: $-40\text{ °C} \leq T_a \leq +70\text{ °C}$ for "T" or "E" types

(Item 14 in the schematic legend) or

T4: $0\text{ °C} \leq T_a \leq +50\text{ °C}$ for "S" types

(Item 14 in the schematic legend) or

Environmental class and temperature code for RS40 types:

T3: $-40\text{ °C} \leq T_a \leq +70\text{ °C}$ for "T" or "E" types

(Item 14 in the schematic legend) or.

T4: $-40\text{ °C} \leq T_a \leq +60\text{ °C}$ for "T" or "E" types

(item 14 of nomenclature breakdown).

T4: $0\text{ °C} \leq T_a \leq +60\text{ °C}$ for "S" types

(item 14 of nomenclature breakdown).

- The modules shall be installed in a suitable enclosure in accordance with EN 60079-15 providing a degree of protection of at least IP54 according to EN 60529, taking into account the environmental conditions under which the equipment will be used.

- When the temperature under rated conditions exceeds 70 °C at the cable or conduit entry point, or 80 °C at the branching point of the conductors, the temperature specification of the selected cable and cable entries shall be in compliance with the actual measured temperature values.
- Provisions shall be made to prevent the rated voltage from being exceeded by transient disturbances of more than 119 V.
- Connectors shall be connected or disconnected exclusively in dead-voltage state.



- DIP switches must be actuated in de-energized state only.
- The USB port shall remain disconnected.

■ **E marking**

The labeled devices comply with the regulations contained in the following European directive(s):

RPS90/48V LV:

72/245/EWG, 2004/104/EG, 2009/19/EG

Guideline for standardizing the regulations of member states relating to radio interference from motor vehicles. Certified devices are marked with an e1 type approval indicator.

- For use in connection with a suitable type approved power supply only.

■ **CE marking**

The labeled devices comply with the regulations contained in the following European directive(s):

2011/65/EU (RoHS)

Directive of the European Parliament and of the Council on the restriction of the use of certain hazardous substances in electrical and electronic equipment.

2014/30/EU (EMC)

Directive of the European Parliament and the council for standardizing the regulations of member states with regard to electromagnetic compatibility.

Applies only to power supply unit RPS90/48V HV:

2014/35/EU

Directive of the European Parliament and the council for standardizing the regulations of member states with regard to electrical equipment for use within specific voltage limits.

In accordance with the above-named EU directive(s), the EU conformity declaration will be at the disposal of the relevant authorities at the following address:

Hirschmann Automation and Control GmbH
Stuttgarter Str. 45-51
72654 Neckartenzlingen
Germany
Tel.: +49 1805 141538

The device can be used in the industrial sector.

- ▶ Interference immunity: EN 61000-6-2
- ▶ Emitted interference: EN 55022

Warning! This is a class A device. This device can cause interference in living areas, and in this case the operator may be required to take appropriate measures.

Note: The assembly guidelines provided in these instructions must be strictly adhered to in order to observe the EMC threshold values.

■ **LED or laser components**

LED or LASER components according to IEC 60825-1 (2014):

CLASS 1 LASER PRODUCT

CLASS 1 LED PRODUCT

■ **FCC note:**

This device complies with part 15 of the FCC rules. Operation is subject to the following two conditions: (1) this device may not cause harmful interference; (2) this device must accept any interference received, including interference that may cause undesired operation.

Appropriate testing has established that this device fulfills the requirements of a class A digital device in line with part 15 of the FCC regulations.

These requirements are designed to provide sufficient protection against interference when the device is being used in a business environment.

The device creates and uses high frequencies and can also radiate these frequencies. If it is not installed and used in accordance with this operating manual, it can cause radio transmission interference. The use of this device in a residential area can also cause interference, and in this case the user is obliged to cover the costs of removing the interference.

■ **Recycling note**

After usage, this device must be disposed of properly as electronic waste, in accordance with the current disposal regulations of your county, state, and country.

About this Manual

The “Installation” user manual contains a device description, safety instructions, a description of the display, and the other information that you need to install the device.

The Industrial HiVision Network Management software provides you with additional options for smooth configuration and monitoring:

- ▶ ActiveX control for SCADA integration
- ▶ Auto-topology discovery
- ▶ Browser interface
- ▶ Client/server structure
- ▶ Event handling
- ▶ Event log
- ▶ Simultaneous configuration of multiple devices
- ▶ Graphical user interface with network layout
- ▶ SNMP/OPC gateway

Key

The symbols used in this manual have the following meanings:

▶	Listing
□	Work step
■	Subheading

1 Description

You can choose from between a wide range of variants. You have the option to set up your device individually based on different criteria:

- ▶ Number of ports
- ▶ Transmission speed
- ▶ Media type
- ▶ Types of connectors
- ▶ Temperature range
- ▶ Certifications
- ▶ Software variant

The RS20/22/30/32/40 devices are designed for the special requirements of industrial automation. They meet the relevant industry standards, provide very high operational reliability, even under extreme conditions, and also long-term reliability and flexibility.

The devices allow you to set up switched industrial Ethernet networks that conform to the IEEE 802.3 standard.

The devices work without a fan.

The voltage is supplied redundantly.

The following installation options are available:

- ▶ simply snapping them onto a DIN rail
- ▶ mounting them on a wall (only RS22/RS32)

Depending on the device variant, you can choose various media to connect terminal devices and other infrastructure components:

- ▶ twisted pair cable
- ▶ multimode F/O
- ▶ singlemode F/O

The twisted pair ports support:

- ▶ Autocrossing
- ▶ Autonegotiation
- ▶ Autopolarity

There are convenient options for managing the device. Administer your devices via:

- ▶ a Web browser
- ▶ Telnet
- ▶ SSH
- ▶ HiDiscovery (Software for putting the device into operation)
- ▶ network management software (e.g. Industrial HiVision)
- ▶ a V.24 interface (locally on the device)

The ring redundancy concept allows the network to be reconfigured quickly after a failure.

Product configuration data can be provided by:

- ▶ diagnosis displays
- ▶ displaying the operating parameters
- ▶ a label area for the IP address

The devices provide you with a large range of functions, which the manuals for the operating software inform you about. You can download these manuals as PDF files from the Internet on the Hirschmann product pages (www.hirschmann.com).

The Hirschmann network components help you ensure continuous communication across all levels of the company.

1.1 Description of the device variants

The devices differ with regard to the range of software functions, the number of interfaces, and the media type for connecting segments.

The table below shows three port categories for each product variant: uplink ports, PoE ports and other ports. The table also shows for each product category the number of ports you can select, and the type of ports. In the column for the port type, the abbreviations F/O (optical fiber) and TP (twisted pair) indicate the media type, while the abbreviations DSC, ST, SFP and RJ45 indicate the socket type.

Variant	Uplink ports		Other ports		PoE ports included	
	Number	Type	Number	Type	Number	Type
RS20-...	2	Ports 1 and 2 10/100 Mbit/s, media selectable, DSC, ST, RJ45	2, 6, 14, 22	10/100 Mbit/s, TP, RJ45	—	—
	3	Ports 1 to 3 10/100 Mbit/s, media selectable, DSC, ST, RJ45	6, 14, 22	10/100 Mbit/s, TP, RJ45	—	—
RS22-...	2	Ports 1 and 2 10/100 Mbit/s, media selectable, DSC, ST, RJ45	6, 14, 22	10/100 Mbit/s, TP, RJ45	4	10/100 Mbit/s, TP, RJ45
	3	Ports 1 to 3 10/100 Mbit/s, media selectable, DSC, ST, RJ45	6, 14, 22	10/100 Mbit/s, TP, RJ45	4	10/100 Mbit/s, TP, RJ45
RS30-...	2	Ports 1 and 2 1000 Mbit/s, media selectable, SFP, RJ45	8, 16, 24	10/100 Mbit/s, TP, RJ45	—	—
	4	Ports 1+2, 3+4 2x100/1000 Mbit/s, 2x 100 Mbit/s, F/O, SFP	6, 14, 22	10/100 Mbit/s, TP, RJ45	—	—

Table 1: Number and type of ports

Variant	Uplink ports		Other ports		PoE ports included	
	Number	Type	Number	Type	Number	Type
RS32-...	2	Ports 1 and 2 1000 Mbit/s, media selectable, SFP, RJ45	8, 16, 24	10/100 Mbit/s, TP, RJ45	4	10/100 Mbit/s, TP, RJ45
	4	Ports 1+2, 3+4 2x100/1000 Mbit/s, 2x 100 Mbit/s, F/O, SFP	6, 14, 22	10/100 Mbit/s, TP, RJ45	4	10/100 Mbit/s, TP, RJ45
RS40-...	4	Ports 1 to 4 4 combo ports: 100/1000 Mbit/s, F/O, SFP 10/100/1000 Mbit/s, TP, RJ45	5	10/100/ 1000 Mbit/s, TP, RJ45	—	—

Table 1: Number and type of ports

1.1.1 Combination options of the device variants RS20/RS30/RS22/RS32

The product designation of your device is made from combining the desired product characteristics in accordance with the following table. You will find the corresponding short designation in columns 3 and 4.

Position	Characteristic	Ident. Ident.2 a)	Property	
1 to 4	Product	RS20	Rail Switch without gigabit ports	
		RS30	Rail Switch with gigabit ports	
		RS22	Rail Switch without gigabit ports, with PoE ^{b)c)}	
		RS32	Rail Switch with gigabit ports, with PoE ^{d)e)}	
5	- (hyphen)	-		
6 bis 7	Number of 10/100 Mbit/s ports	04	4 × 10/100 Mbit/s Ethernet	
		08	8 × 10/100 Mbit/s Ethernet	
		09	9 × 10/100 Mbit/s Ethernet	
		16	16 × 10/100 Mbit/s Ethernet	
		17	17 × 10/100 Mbit/s Ethernet	
		24	24 × 10/100 Mbit/s Ethernet	
		25	25 × 10/100 Mbit/s Ethernet	
8 and 9	Number of 1000 Mbit/s ports	00	0 × 1000 Mbit/s Ethernet	
		02	2 × 1000 Mbit/s Ethernet (not for 4-port devices) ^{f)}	
10 and 11 ^{a)}	Uplink port(s) 1 port (Ident. column) or alternatively 2 ports (Ident.2 column)	T1	Twisted Pair TX, RJ45	
		M2	MM ^{g)}	Multimode FX, DSC, 100 Mbit/s
		M4	NN ^{h)}	Multimode FX, ST, 100 Mbit/s
		S2	VV ⁱ⁾	Singlemode FX, DSC, 100 Mbit/s
		S4	UU ^{j)}	Singlemode FX, ST, 100 Mbit/s
		E2	EE ^{k)l)}	Singlemode+ FX, DSC, 100 Mbit/s
		L2	LL ^{m)}	Singlemode Longhaul, DSC, 100 Mbit/s
		G2	GG ⁿ⁾	Singlemode Longhaul FX DSC 200 km, 100 Mbit/s
		O6	OO ^{o)p)}	SFP slot, 100 ^{q)} /1000 Mbit/s
Z6	ZZ ^{r)s)}	SFP slot, 100 Mbit/s		
12 and 13 ^{a)}	See items 10 and 11			
14	Temperature range	S	Standard: +32 °F to +140 °F (0 °C to +60 °C) ^{t)}	
		T	Extended -40 °F to +158 °F (-40 °C to +70 °C) ^{u)v)}	
		E	Extended -40 °F to +158 °F (-40 °C to +70 °C), Conformal Coating ^{w)x)y)}	
	Voltage range incl. maximum tolerances	D ^{z)}	9.6 V DC to 60 V DC or 18 V AC to 30 V AC	
	P ^{aa)}	47 V DC to 52 V DC (PoE)		

Table 2: Combination options of the device variants RS20/RS30/RS22/RS32

Position	Characteristic	Ident. Ident.2 a)	Property
16	Approval	A	CE, UL 508, ISA 12.12.01 (UL 1604)
		H	CE, UL 508, ISA 12.12.01 (UL 1604), GL, Railway (along track), Sub Station
		B ^{ab)}	CE, UL 508, ISA 12.12.01 (UL 1604), GL, Railway (along track), Sub Station, Hazardous Location/ATEX/IECEX
17	Software variant	E	Enhanced
		P	Professional

Table 2: *Combination options of the device variants RS20/RS30/RS22/RS32*

- a. For device variants with 2 uplink ports you use the "Ident." column for items 10+11 and for items 12+13.
For device variants with 3 uplink ports you use the "Ident.2" column for items 10+11 and the "Ident." column for items 12+13.
For device variants with 4 uplink ports you use the "Ident.2" column for items 10+11 and for items 12+13.
- b. Not in combination with "04×100 Mbit/s Ethernet".
- c. The last 4 ports of the device have PoE (Power over Ethernet).
- d. Not in combination with "04×100 Mbit/s Ethernet".
- e. The last 4 ports of the device have PoE (Power over Ethernet).
- f. Not in combination with "04×100 Mbit/s Ethernet".
- g. For RS20-0900..., RS20-1700..., RS20-2500...;
RS22-0900..., RS22-1700..., RS22-2500...
- h. For RS20-0900..., RS20-1700..., RS20-2500...;
RS22-0900..., RS22-1700..., RS22-2500...
- i. For RS20-0900..., RS20-1700..., RS20-2500...;
RS22-0900..., RS22-1700..., RS22-2500...
- j. For RS20-0900..., RS20-1700..., RS20-2500...;
RS22-0900..., RS22-1700..., RS22-2500...
- k. For RS20-0900..., RS20-1700..., RS20-2500...;
RS22-0900..., RS22-1700..., RS22-2500...
- l. Devices with ports with product code E2 or EE: only certification "A" available (see product code for item 16).
- m. For RS20-0900..., RS20-1700..., RS20-2500...;
RS22-0900..., RS22-1700..., RS22-2500...
- n. For RS20-0900..., RS20-1700..., RS20-2500...;
RS22-0900..., RS22-1700..., RS22-2500...
- o. Not in combination with "04×100 Mbit/s Ethernet".
- p. In connection with "2nd uplink port" "ZZ" and "1st uplink port" "OO".
- q. Only for "OO" combination
- r. In combination with "2nd uplink port" "ZZ" and "1st uplink port" "OO".
- s. Not in combination with "04×100 Mbit/s Ethernet".
- t. With a UL-508, ATEX/IECEX, or ISA 12.12.01 certification, the maximum operating temperature for the standard 'S' temperature range for PoE-capable devices (RS22-..., RS32-...) is +122 °F (+50 °C).
- u. The extended 'E' temperature range for the PoE-capable devices is -40 °F to +140 °F (-40 °C to +60 °C).
With a UL-508, ATEX/IECEX, or ISA 12.12.01 approval, the maximum operating temperature for the extended 'E' temperature range for PoE-capable devices (RS22-..., RS32-...) is +122 °F (+50 °C).
- v. Not when using GG or G2 transceivers.
- w. The extended 'T' temperature range for the PoE-capable devices is -40 °F to +140 °F (-40 °C to +60 °C).
With a UL-508, ATEX/IECEX, or ISA 12.12.01 approval, the maximum operating temperature for the extended 'T' temperature range for PoE-capable devices (RS22-..., RS32-...) is +122 °F (+50 °C).
- x. Not when using GG or G2 transceivers.
- y. In combination with "2nd uplink port" "ZZ" and "1st uplink port" "OO".
- z. Not for PoE-capable devices (RS22-..., RS32-...).
- aa. For PoE-capable devices (RS22-..., RS32-...).
- ab. Without railway approval EN 50155 (Train).

■ Examples for product name

RS20- 09 00 MM M2 S D A P	RS20-	Rail Switch without gigabit ports
	09	9 × 100 Mbit/s Ethernet ports
	00	0 × 100 Mbit/s Ethernet ports
	MM	Port 1 + 2 = 2 × Multimode FX, DSC, 100 Mbit/s
	M2	Port 3 = Multimode FX, DSC, 100 Mbit/s
	S	Temperature range: Standard: +32 °F ... +140 °F (0 °C ... +60 °C)
	D	Voltage range: 9.6 V DC to 60 V DC or 18 V AC to 30 V AC
	A	Approvals: CE, UL 508, ISA 12.12.01 (UL 1604)
	P	Software variant: Professional

Table 3: Example of RS20 with 3 uplink ports: RS20-0900MMM2SDAP

RS30- 08 02 O6 T1 T D A E	RS30-	Rail Switch with gigabit ports
	08	8 × 100 Mbit/s Ethernet ports
	02	2 × 100 Mbit/s Ethernet ports
	O6	Port 1 = SFP slot, 1000 Mbit/s
	T1	Port 2 = twisted pair TX, RJ45 connector, 1000 Mbit/s
	T	Temperature range Extended -40 °F to +158 °F (-40 °C to +70 °C)
	D	Voltage range: 9.6 V DC to 60 V DC or 18 V AC to 30 V AC
	A	Approvals: CE, UL 508, ISA 12.12.01 (UL 1604)
	E	Software variant: Enhanced

Table 4: Example of RS30 with 2 uplink ports: RS30-0802O6T1TDAE

Additional examples of devices with 3 or 4 uplink ports:

- ▶ RS20-0900**NNM4**TDAE for RS20 with 3 uplink ports (ST)
 - NN**: 2 × Multimode FX, ST, 100 Mbit/s (ports 1 and 2)
 - M4**: 1 × Multimode FX, ST, 100 Mbit/s (port 3)
- ▶ RS30-2402**OOZZ**TDAP for RS30 with 4 uplink ports (SFP)
 - OO**: 2 × SFP slot, 1000 Mbit/s (ports 1 and 2)
 - ZZ**: 2 × SFP slot, 100 Mbit/s (ports 3 und 4)

Example of device with Power over Ethernet:

- ▶ RS32-0802**O6T1**SPAP for RS32 with 2 uplink ports and PoE
 - O6**: 1 × SFP slot, 1000 Mbit/s (port 1)
 - T1**: 1 × twisted pair TX, RJ45, 1000 Mbit/s (port 2)
 - P**: Voltage range 47 V DC to 52 V DC (PoE)

1.1.2 Combination options for the RS40 device variants

The product designation of your device is made from combining the desired product characteristics in accordance with the following table. The corresponding short designation is in column 3.

Position	Characteristic	Ident.	Property
1 to 4	Product	RS40	Rail Switch with gigabit ports
5	- (hyphen)	-	
6 to 7	Number of 10/100 Mbit/s ports	00	0 × 10/100 Mbit/s Ethernet
8 and 9	Number of 1000 Mbit/s ports	09	9 × 1000 Mbit/s Ethernet
10 and 11	1. + 2. Uplink port	CC	2 × Combo port multirate (SFP slot: 100/1000 Mbit/s; alternatively twisted pair RJ45 socket: 10/100/1000 Mbit/s)
12 and 13	3. + 4. Uplink port	CC	2 × Combo Port multirate (SFP-slot: 100/1000 Mbit/s; alternatively twisted pair RJ45 socket: 10/100/1000 Mbit/s)
14	Temperature range	S	Standard: +32 °F to +140 °F (0 °C to +60 °C)
		T	Extended: -40 °F to + 158 °F (-40 °C to +70 °C)
		E	Extended: -40 °F to + 158 °F (-40 °C to +70 °C), Conformal Coating
15	Voltage range	D	9.6 V DC to 60 V DC or 18 V AC to 30 V AC
16	Approval	A	CE, UL 508, ISA 12.12.01 (UL 1604)
		H	CE, UL 508, GL, Rail (along track), Substation, ISA 12.12.01 (UL 1604)
		B	CE, UL 508, GL, Rail (along track), Substation, ISA 12.12.01 (UL 1604), Hazardous Location/ATEX/IECEX
17	Software variant	E	Enhanced
		P	Professional

Table 5: Combination options for the RS40 device variants

■ Examples for product name

RS40- 00 09 CC CC E	RS40-	Rail Switch with gigabit ports
	00	0 × 100 Mbit/s Ethernet ports
	09	9 × 1000 Mbit/s Ethernet ports
	CC	Port 1 + 2 = Combo port: SFP slot (100/1000 Mbit/s), alternatively: RJ45 connector (10/100/1000 Mbit/s)
	CC	Port 3 + 4 = Combo port: SFP slot (100/1000 Mbit/s), alternatively: RJ45 connector (10/100/1000 Mbit/s)
	E	Temperature range Extended (-40 °F to +158 °F; -40 °C to +70 °C) with Conformal Coating

Table 6: Example of RS40 with 4 uplink ports: RS40-0009CCCCEDAP

D V P	D	Voltage range: 9.6 V DC to 60 V DC or 18 V AC to 30 V AC
	A	Approvals: CE, UL 508, ISA 12.12.01 (UL 1604)
	P	Software variant: Professional

Table 6: Example of RS40 with 4 uplink ports: RS40-0009CCCCEDAP

1.1.3 Number of ports and media for RS20-...

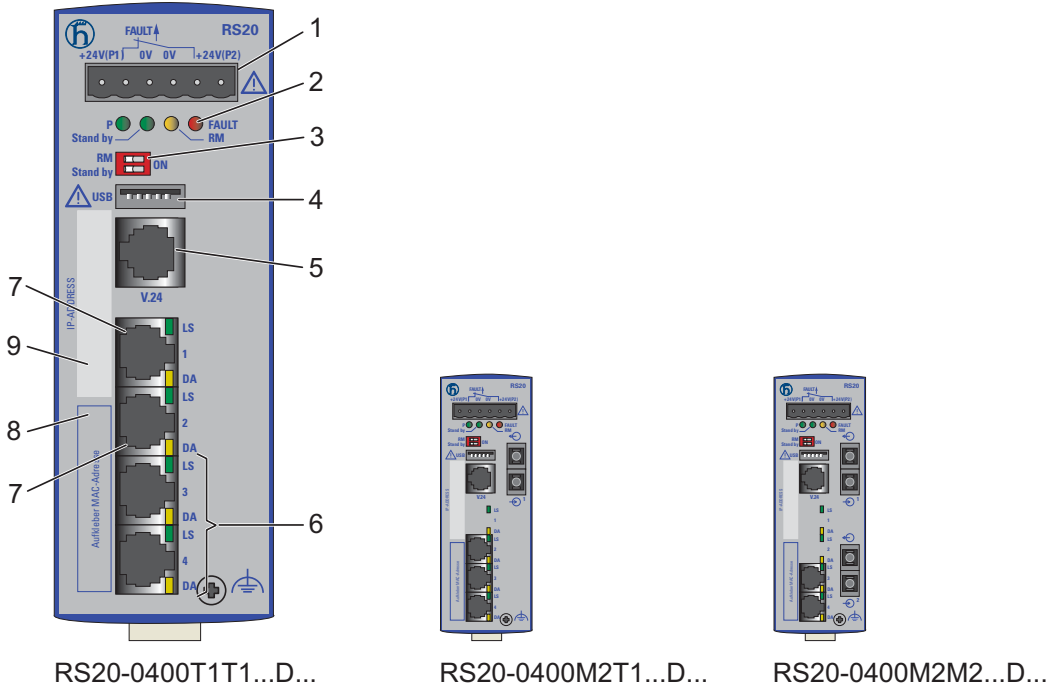

Figure 1: Device variants with 4 × 10/100 Mbit/s ports (RS20-0400...)

- 1 – plug-in terminal block, 6-pin
- 2 – LED display elements
- 3 – 2-pin DIP switch
- 4 – USB interface
- 5 – V.24 connection for external management
- 6 – ports in compliance with 10/100BASE-T(X) (RJ45 connections)
- 7 – port 1 + port 2, free choice of connections:
 - T1: Twisted-pair T(X), RJ45, 10/100 Mbit/s
 - M2: Multimode FX, DSC, 100 Mbit/s
 - M4: Multimode FX, ST, 100 Mbit/s
 - S2: Singlemode FX, DSC, 100 Mbit/s
 - S4: Singlemode FX, ST, 100 Mbit/s
 - L2: Singlemode Longhaul FX, DSC, 100 Mbit/s
 - G2: Singlemode Longhaul+ FX, DSC, 100 Mbit/s, 200 km
- 8 – MAC address field
- 9 – IP address field

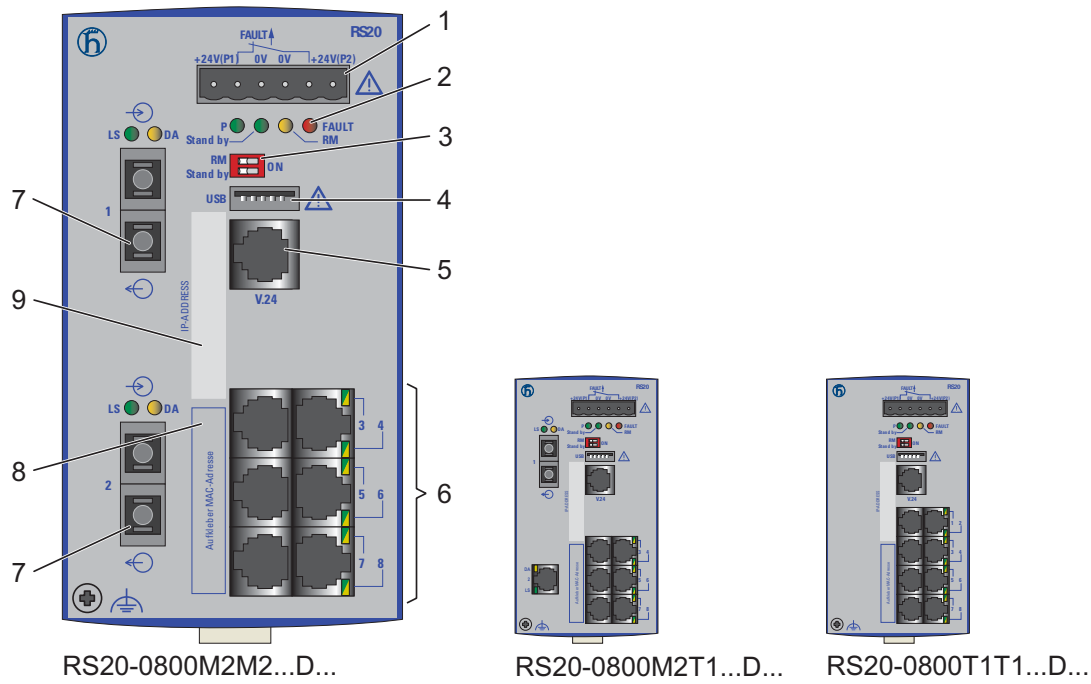

Figure 2: Device variants with 8 × 10/100 Mbit/s ports (RS20-0800...)
1 to 9 – see figure 1

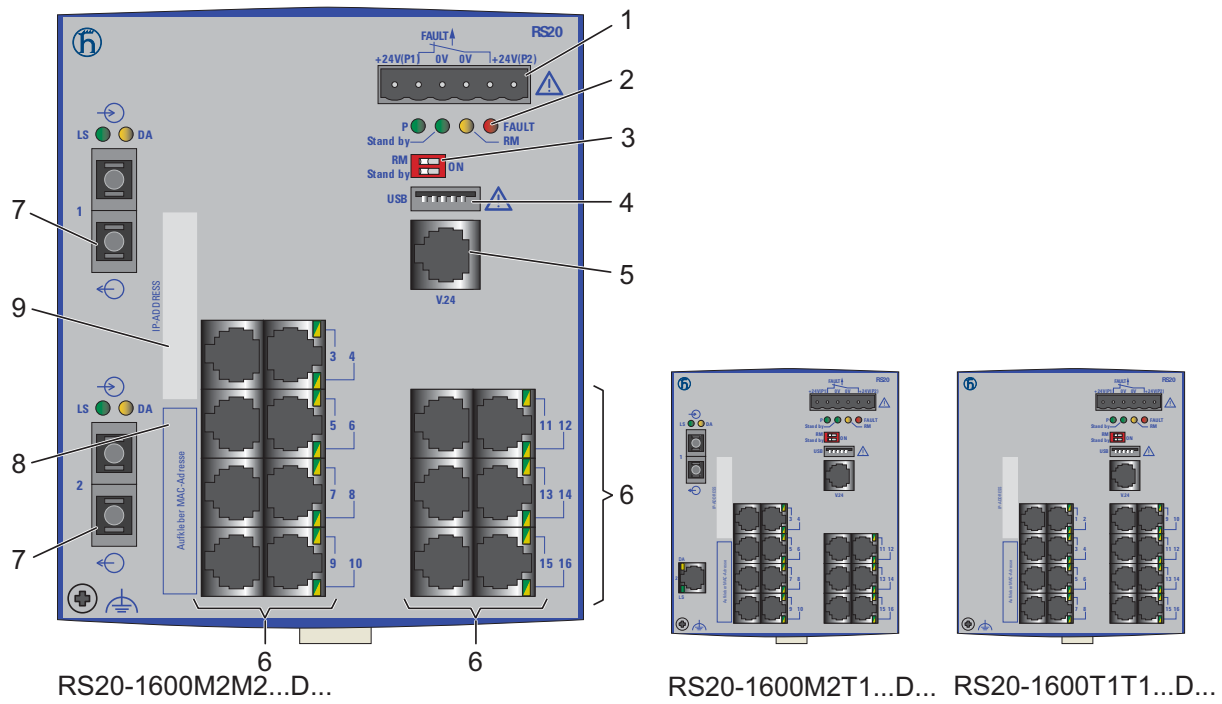

Figure 3: Device variants with 16 × 10/100 Mbit/s ports (RS20-1600...)
1 to 9 – see figure 1

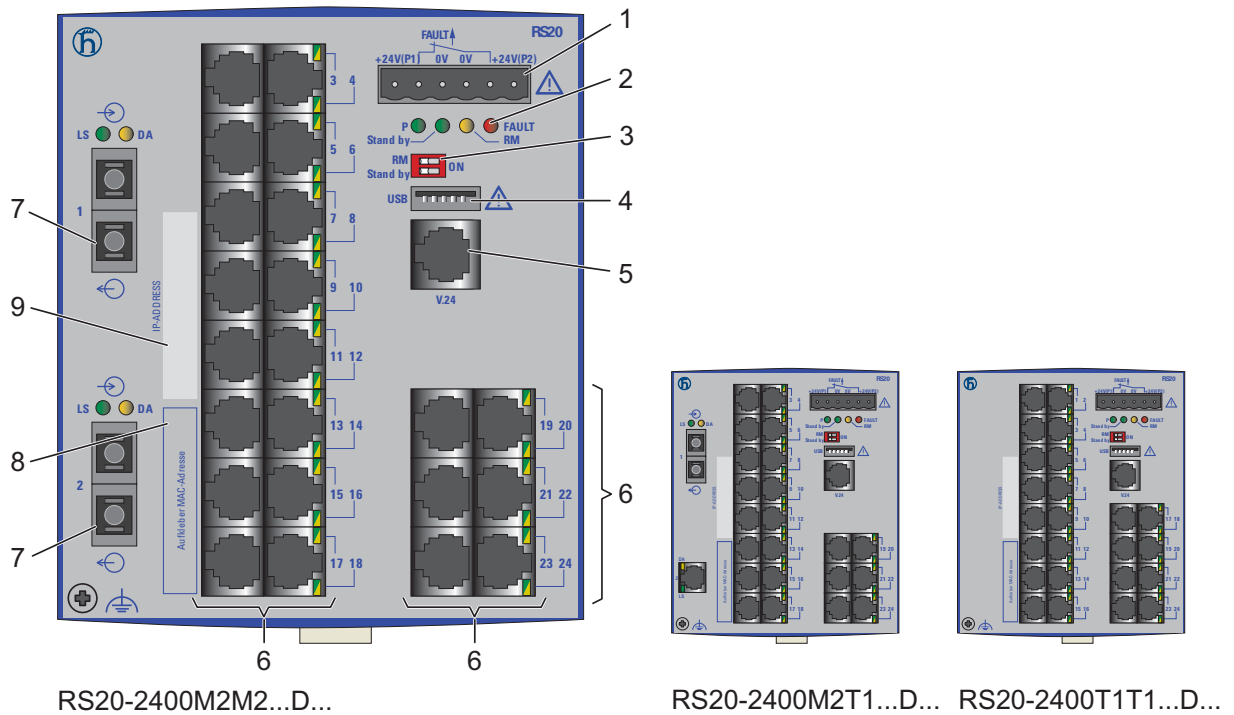

Figure 4: Device variants with 24 x 10/100 Mbit/s ports (RS20-2400...)
1 to 9 – see figure 1

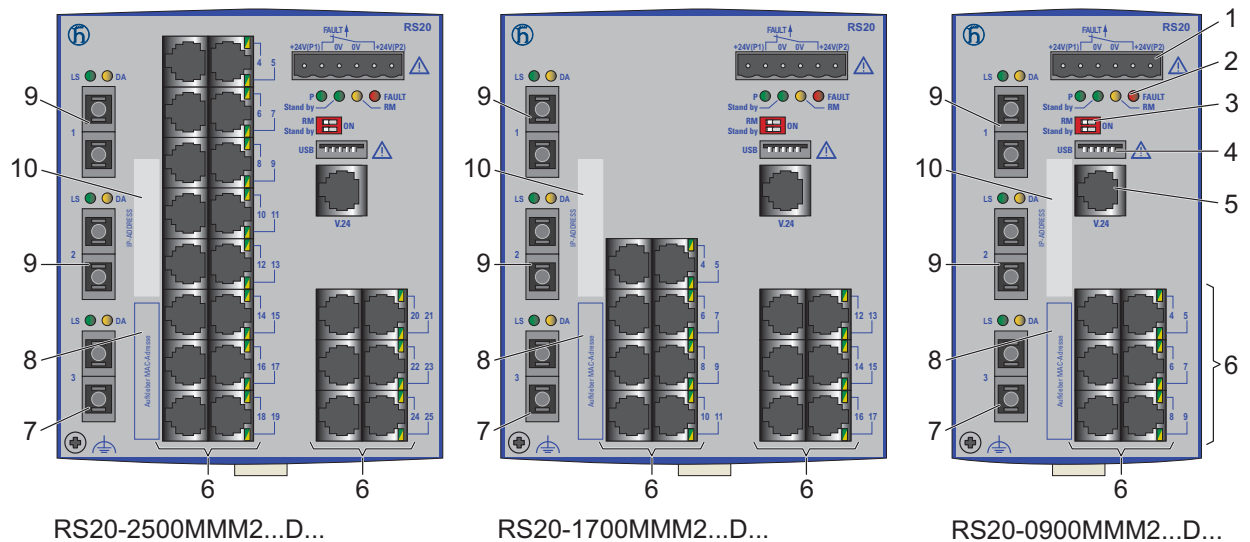

Figure 5: Device variants with 3 uplink ports (100 Mbit/s)
1 to 6 – see figure 1

7 – port 3, free choice of connection:

T1: Twisted-pair T(X), RJ45, 10/100 Mbit/s

M2: Multimode FX, DSC, 100 Mbit/s

M4: Multimode FX, ST, 100 Mbit/s

S2: Singlemode FX, DSC, 100 Mbit/s

S4: Singlemode FX, ST, 100 Mbit/s

L2: Singlemode Longhaul FX, DSC, 100 Mbit/s

G2: Singlemode Longhaul+ FX, DSC, 100 Mbit/s, 200 km

8 – MAC address field

- 9 – port 1 + port 2, free choice of connections:
 - MM: Multimode FX, DSC, 100 Mbit/s
 - NN: Multimode FX, ST, 100 Mbit/s
 - VV: Singlemode FX, DSC, 100 Mbit/s
 - UU: Singlemode FX, ST, 100 Mbit/s
 - LL: Singlemode Longhaul FX, DSC, 100 Mbit/s
 - GG: Singlemode Longhaul+ FX, DSC, 100 Mbit/s, 200 km
- 10 – IP address field

1.1.4 Number of ports and media for RS30-...

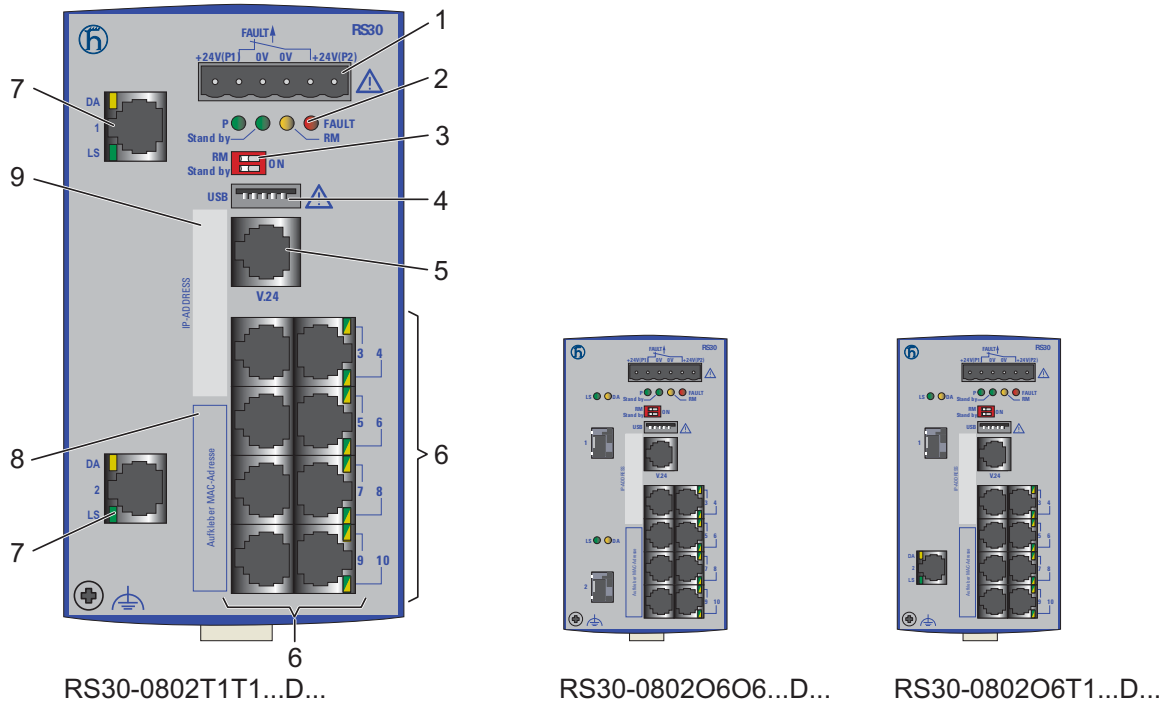
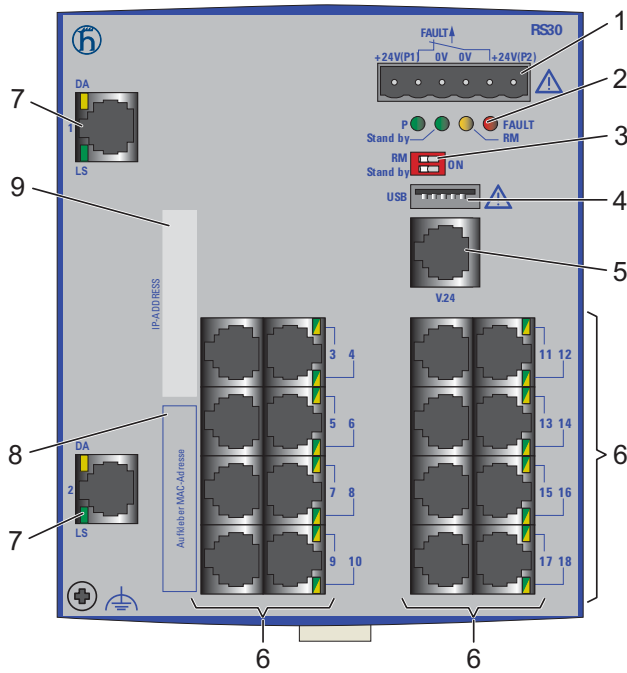
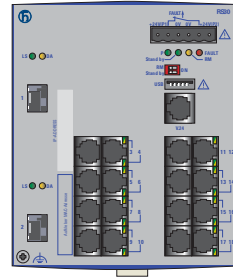

Figure 6: Device variants with 2 × 1000 Mbit/s ports and 8 × 10/100 Mbit/s ports (RS30-0802...)

- 1 – plug-in terminal block, 6-pin
- 2 – LED display elements
- 3 – 2-pin DIP switch
- 4 – USB interface
- 5 – V.24 connection for external management
- 6 – ports in compliance with 10/100BASE-T(X) (RJ45 connections)
- 7 – port 1 + port 2, free choice of connections:
 - T1: Twisted-pair T(X), RJ45, 10/100/1000 Mbit/s
 - O6: SX/LX, SFP slot, 1000 Mbit/s
- 8 – MAC address field
- 9 – IP address field



RS30-1602T1T1...D...



RS30-1602O6O6...D...

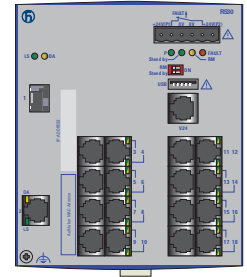

RS30-1602O6T1...D...

Figure 7: Device variants with 2 × 1000 Mbit/s ports and 16 × 10/100 Mbit/s ports (RS30-1602...)
1 to 9 – see figure 6

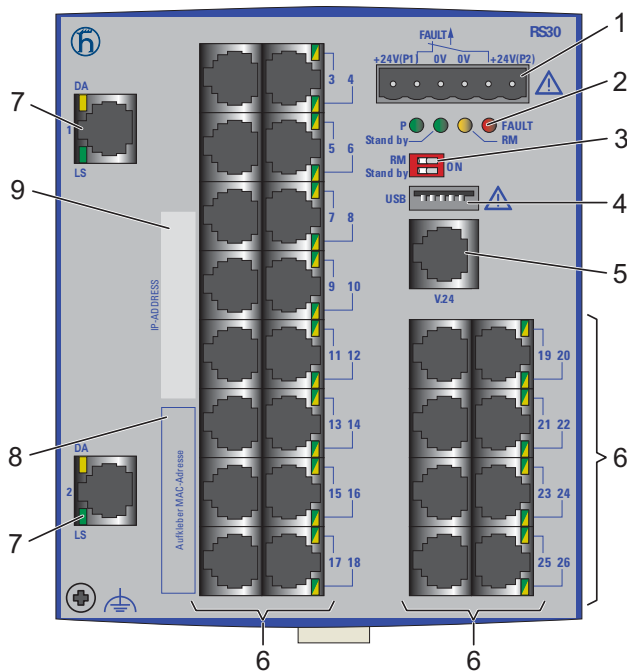

RS30-2402T1T1...D...

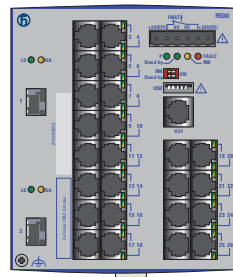

RS30-2402O6O6...D...

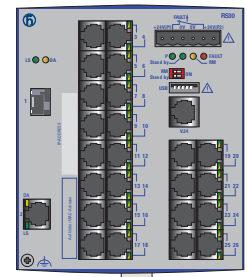

RS30-2402O6T1...D...

Figure 8: Device variants with 2 × 1000 Mbit/s ports and 24 × 10/100 Mbit/s ports (RS30-2402...)
1 to 9 – see figure 6

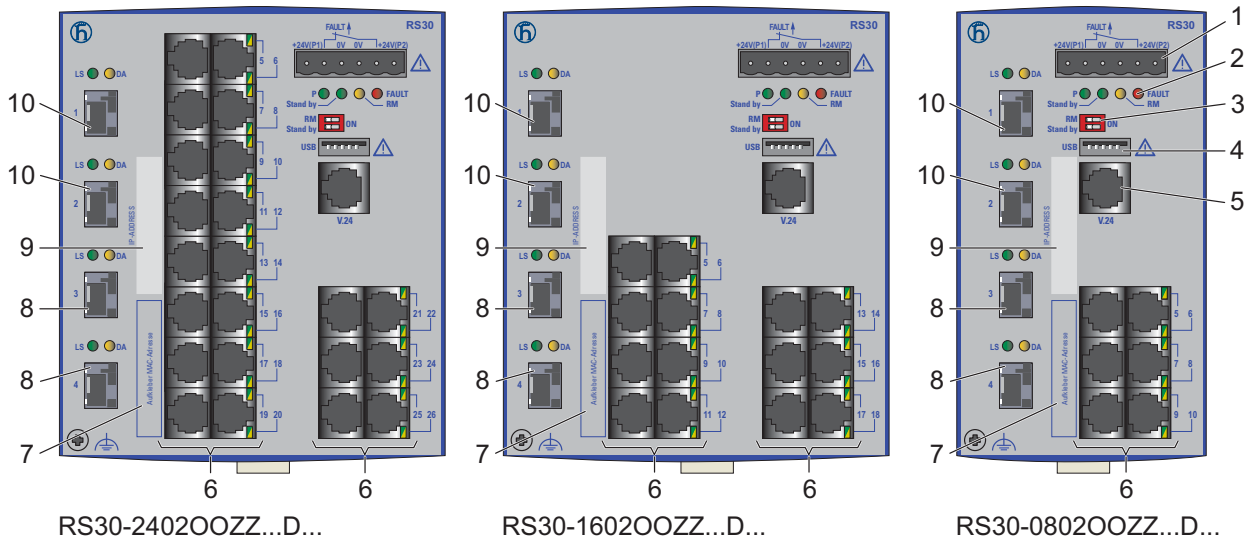

Figure 9: Device variants with 4 uplink ports

1 to 6 – see [figure 6](#)

7 – MAC address field

8 – port 3 + port 4:

ZZ: FX, SFP slot, 100 Mbit/s

9 – IP address field

10 – port 1 + port 2:

OO: FX/SX/LX, SFP slot, 100/1000 Mbit/s

1.1.5 Number of ports and media for RS40-...

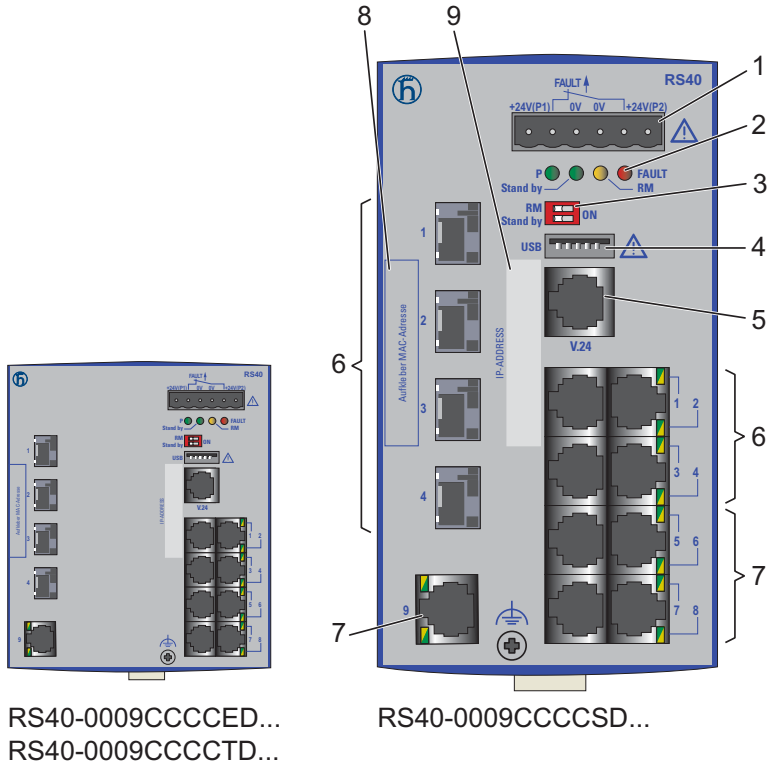

Figure 10: Device variants with 9 × 1000 Mbit/s ports (RS40-0009...)

1 to 5 and 8 to 9 – see [figure 6](#)

6 – port 1 to port 4: combo ports (CC):

FX/SX/LX, SFP slot, 100 or 1000 Mbit/s

Alternatively: T(X), RJ45 connections, 10/100/1000 Mbit/s

7 – ports in compliance with 10/100/1000BASE-T(X) (RJ45 connections)

1.2 Device variants with PoE (optional)

1.2.1 Number of ports and media for devices with PoE

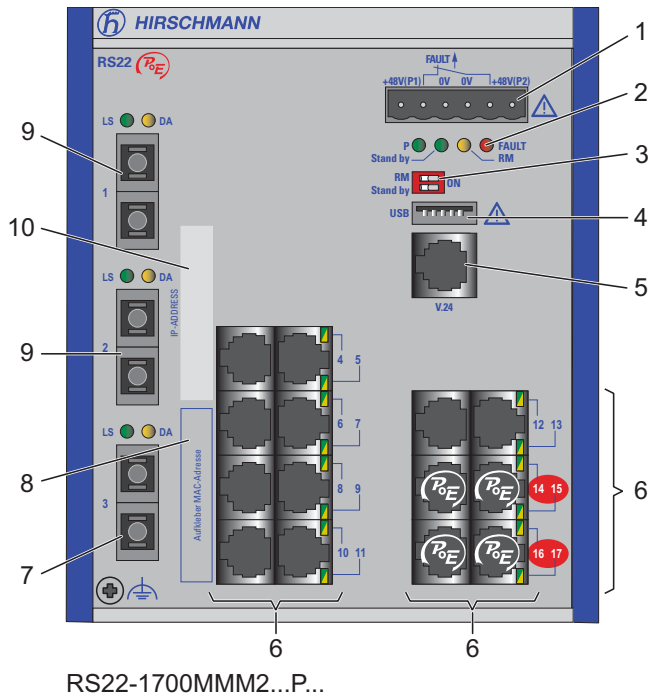

Figure 11: RS22 device variants with PoE (example: RS22-1700MMM2...P...)
1 to 5 and 7 to 9 – see [figure 5](#)
6 – ports in compliance with 10/100BASE-T(X) (RJ45 connections; the PoE-capable ports 14 to 17 are indicated accordingly)

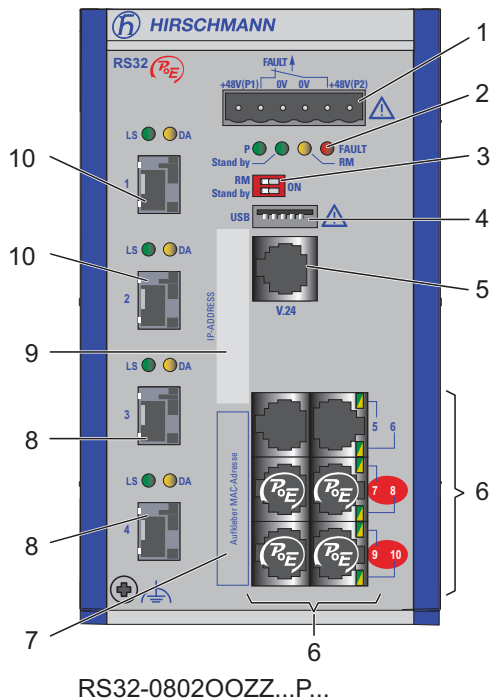

Figure 12: RS32 device variants with 4 uplink ports (example: RS32-08020OZZ...P...)

1 to 5 and 7 to 9 – see [figure 9](#)

6 – ports in compliance with 10/100BASE-T(X) (RJ45 connections; the PoE-capable ports 7 to 10 are indicated accordingly)

Device variants RS22-... and RS32-... support Power over Ethernet (PoE) in accordance with IEEE 802.3af.

They allow the connection and remote supply of, for example, IP telephones (Voice over IP), webcams, sensors, printer servers and WLAN access points via 10BASE-T/100BASE-TX. With PoE, these terminal devices are powered by the twisted-pair cable.

The RS22-... and RS32-... devices provide four 10BASE-T/100BASE-TX ports (RJ45 sockets) for connecting network segments or PoE terminal devices (PD, Powered Device) for all IEEE802.3af classes up to a maximum power output of 15.4 W.

The four PoE-capable ports are the four bottom ports on the right side of the device (see figures in section [“Number of ports and media for devices with PoE”](#) on page 34. The PoE ports are indicated in red on the device).

The voltage is supplied through the wire pairs transmitting the signal (phantom voltage). The individual ports are not electrically insulated from each other.

The following conditions are met in accordance with IEEE 802.3af:

- ▶ Endpoint PSE
- ▶ Alternative A

1.2.2 PoE power units

The following PoE power units are available for supplying the devices with PoE voltage:

- ▶ **RPS90/48V LV:** Low-voltage PoE power unit
 - ▶ Input voltage range: 24 V DC to 48 V DC
 - ▶ Power output at up to +60 °C: 90 W
 - ▶ Power output at +60 °C to +70 °C: 60 W
- ▶ **RPS90/48V HV:** High-voltage PoE power unit
 - ▶ Input voltage range:
60 V DC to 250 V DC or 110 V AC to 230 V AC
You can choose between a DC or AC voltage connection.
 - ▶ Power output at up to +60 °C: 90 W
 - ▶ Power output at +60 °C to +70 °C: 60 W

The output voltage can be set in the range from 48 V DC to 54 V DC.
The default setting for the output voltage is 48 V DC.

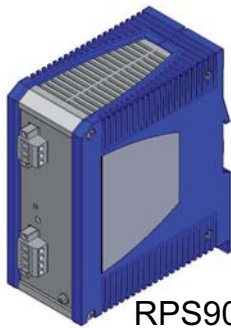

RPS90/48V HV

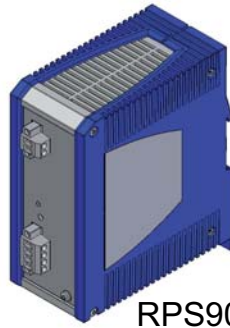

RPS90/48V LV

1.3 Ethernet ports

You can connect end devices and other segments to the device ports using twisted pair cables or optical fibers (F/O).

1.3.1 10/100/1000 Mbit/s twisted pair port

This port is an RJ45 socket.

The 10/100/1000 Mbit/s twisted pair port offers you the ability to connect network components according to the IEEE 802.3 10BASE-T/100BASE-TX/1000BASE-T standard.

This port supports:

- ▶ Autonegotiation
- ▶ Autopolarity
- ▶ Autocrossing (if autonegotiation is activated)
- ▶ 1000 Mbit/s full duplex
- ▶ 100 Mbit/s half-duplex mode, 100 Mbit/s full duplex mode
- ▶ 10 Mbit/s half-duplex mode, 10 Mbit/s full duplex mode

Delivery state: Autonegotiation activated

The socket housing is electrically connected with the front panel.

The pin assignment corresponds to MDI-X.

	Pin	Function
	1	BI_DB+
	2	BI_DB-
	3	BI_DA+
	4	BI_DD+
	5	BI_DD-
	6	BI_DA-
	7	BI_DC+
	8	BI_DC-

Table 7: Pin assignments of the 10/100/1000 Mbit/s twisted pair port in 1000 Mbit/s mode, RJ45 socket, MDI-X mode

1.3.2 10/100 Mbit/s twisted pair port

This port is an RJ45 socket.

The 10/100 Mbit/s twisted pair port offers you the ability to connect network components according to the IEEE 802.3 10BASE-T/100BASE-TX standard.

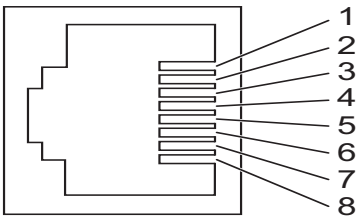
This port supports:

- ▶ Autonegotiation
- ▶ Autopolarity
- ▶ Autocrossing (if autonegotiation is activated)
- ▶ 100 Mbit/s half-duplex mode, 100 Mbit/s full duplex mode
- ▶ 10 Mbit/s half-duplex mode, 10 Mbit/s full duplex mode

Delivery state: Autonegotiation activated

The socket housing is electrically connected with the front panel.

Figure	Pin	Operation	
	1	1+2	One line pair: receiver path
	2	3+6	One line pair: sender path
	3	4,5,7,8	—
	4		
	5		
	6		
	7		
	8		

Table 8: Pin assignment of a TP/TX interface in MDI-X mode, RJ45 socket

1.3.3 10/100 Mbit/s twisted-pair connection PoE (RS22-.../RS32-...)

This port is an RJ45 socket.

The 10/100 Mbit/s PoE port allows you to connect network components as a PoE voltage sink according to the standard IEEE 802.3 10BASE-T/100BASE-TX and IEEE 802.3af.

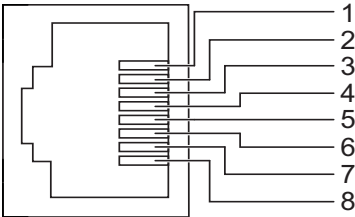
This port supports:

- ▶ Autonegotiation
- ▶ Autopolarity
- ▶ Autocrossing (if autonegotiation is activated)
- ▶ 100 Mbit/s half-duplex mode, 100 Mbit/s full duplex mode
- ▶ 10 Mbit/s half-duplex mode, 10 Mbit/s full duplex mode
- ▶ Power over Ethernet (PoE, at the last four ports of the device)

Delivery state: Autonegotiation activated

The socket housing is electrically connected with the front panel.

The PoE power is supplied via the wire pairs transmitting the signal (phantom voltage).

	Pin	Function	PoE voltage
	1	RD+ Receive path	Minus terminal
	2	RD- Receive path	Minus terminal
	3	TD+ Transmission path	Plus terminal
	6	TD- Transmission path	Plus terminal
	4,5,7,8	—	—

Table 9: Pin assignment 10/100-Mbit/s PoE port, RJ45 socket, MDI-X mode, phantom voltage

1.3.4 1000 Mbit/s F/O port

This port is an SFP slot.

The 1000 Mbit/s F/O port offers you the ability to connect network components according to the IEEE 802.3 100BASE-SX/1000BASE-LX standard.

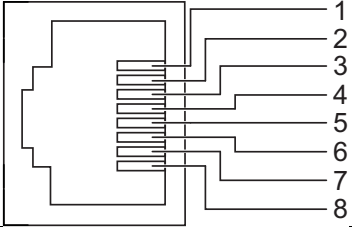
This port supports:

This port supports:

- ▶ Autonegotiation

For device variants with the designation RS30-...02OOZZ... and RS32-...02OOZZ... (4 uplink ports with SFP slot), you have the option of using either Gigabit Ethernet SFP transceivers or Fast Ethernet SFP transceivers at the two top ports, and Fast Ethernet SFP transceivers at the two bottom ports.

[See “Accessories” on page 76.](#)

For the device variants RS40-..., you have the option of using either Gigabit Ethernet SFP transceivers or Fast Ethernet SFP transceivers at the combo ports.

[See “Accessories” on page 76.](#)

Verify that you connect LH ports only with LH ports, SX ports only with SX ports, and LX ports only with LX ports.

1.3.5 100 Mbit/s F/O port

In device variants RS20 and RS22, these ports are DSC connectors or ST connectors.

In device variants RS30, RS32 and RS40, these ports are SFP slots.

The 100 Mbit/s F/O port offers you the ability to connect network components according to the IEEE 802.3 100BASE-FX standard.

This port supports:

- Full or half duplex mode

Default setting: Full duplex

Note: Verify that the LH ports are connected only with LH ports, SM ports only with SM ports, and MM ports only with MM ports.

1.3.6 Gigabit combo port

You have the option of alternatively connecting a twisted pair cable via a RJ45 socket or an optical fiber via a SFP transceiver to a combo port.

You obtain appropriate SFP transceivers as an accessory.

See [“Accessories” on page 76](#).

By inserting a SFP transceiver, you deactivate automatically the corresponding twisted pair interface.

Media type	Connection options		
twisted pair cable		Technical standard	IEEE 802.3 10BASE-T/100BASE-TX/1000BASE-T
		Connection type	RJ45
Fiber optic cable	either	Technical standard	IEEE 802.3 100BASE-FX
		Connection type	Fast Ethernet SFP transceiver
	or	Technical standard	IEEE 802.3 1000BASE-SX/LX
		Connection type	1 Gigabit Ethernet SFP transceiver

Table 10: Combo ports: Connection options

■ **10/100/1000 Mbit/s twisted pair port**

See “10/100/1000 Mbit/s twisted pair port” on page 37.

■ **100/1000 Mbit/s F/O port**

This port is an SFP slot.

The 100/1000 Mbit/s F/O port offers you the ability to connect network components according to the IEEE 802.3 100BASE-FX/1000BASE-SX/1000BASE-LX standard.

This port supports:

- ▶ 1000 Mbit/s full duplex
- ▶ 100 Mbit/s half-duplex mode, 100 Mbit/s full duplex mode

State on delivery:

- ▶ 100 Mbit/s full duplex when using a Fast Ethernet SFP transceiver
- ▶ 1000 Mbit/s full duplex when using a Gigabit Ethernet SFP transceiver

1.4 Display elements

After the supply voltage is set up, the software starts and initializes itself. Afterwards, the device performs a self-test. During this process, various LEDs light up. The process takes around 60 seconds.

■ Device state

These LEDs provide information about conditions which affect the operation of the whole device.



Figure 13: Device status LEDs

P - Power (green/yellow LED)	
Glowing green	Both supply voltages are on
Glowing yellow	There is only one supply voltage (P1 or P2) on
Not glowing	Supply voltages P1 and P2 are too low
FAULT - detected error, signal contact (red LED) ^a	
Glowing red	The signal contact is open, i.e. it is reporting a detected error.
Not glowing	The signal contact is closed, i.e. it is not reporting a detected error.
a. If the manual adjustment is active on the “FAULT” signal contact, then the detected error display is independent of the setting of the signal contact.	
RM - Ring Manager (green/yellow LED)	
Glowing green	RM function active, redundant port disabled
Glowing yellow	RM function active, redundant port enabled
Not glowing	RM function not active
Flashing green	Incorrect configuration of the HIPER-Ring (e.g. the ring is not connected to the ring port).
Stand-by	
Glowing green	Stand-by mode enabled
Not glowing	Stand-by mode not enabled
RM and Stand-by - display saving processes of the AutoConfiguration Adapter (ACA)	
Flashing alternately	Error during saving process.
LEDs flash synchronously, two times a second	Loading configuration from the ACA.
LEDs flash synchronously, once a second	Saving the configuration in the ACA.

■ Port state

The green and yellow LEDs at the individual port display port-related information. During the boot phase, these LEDs are used to display the status of the boot procedure.

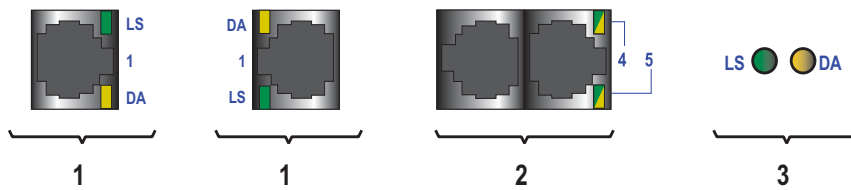

Figure 14: Port status LEDs

1 – Port status LEDs for isolated or single-row RJ45 sockets: one green and one yellow LED per port.

2 – Port status LEDs for double-row RJ45 sockets: one LED per port, glowing/flashing either green or yellow.

3 – Port status LEDs for DSC, ST, SFP

LS - link status (green LED)

Not glowing	No valid connection.
Glowing green	Valid connection.
Flashing green (1 time a period)	Port is switched to stand-by.
Flashing green (3 times a period)	Port is switched off.

DA - data (yellow LED)

Not glowing	No data reception at corresponding port
Flashing yellow	Data reception at corresponding port

1.5 Management interfaces

1.5.1 USB interface

The USB socket is an interface for the local connection of an AutoConfiguration Adapter ACA21-USB. It is used for saving/loading the configuration data and diagnostic information, and for loading the software.

Figure	Pin	Operation
	1	VCC (VBus)
	2	- Data
	3	+ Data
	4	Ground (GND)

Table 11: Pin assignment of the USB interface

1.5.2 V.24 interface (external management)

The V.24 interface is an RJ11 socket.

At the V.24 connection, a serial interface is provided for the local connection of an external management station (VT100 terminal or PC with corresponding terminal emulation) or an AutoConfiguration Adapter ACA 11. This enables you to set up a connection to the Command Line Interface (CLI) and to the system monitor.

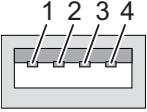
VT 100 terminal settings

Speed	9600 Baud
Data	8 bit
Stopbit	1 bit
Handshake	off
Parity	none

The socket housing is electrically connected to the front panel of the device. The V.24 interface is not electrically isolated from the supply voltage.

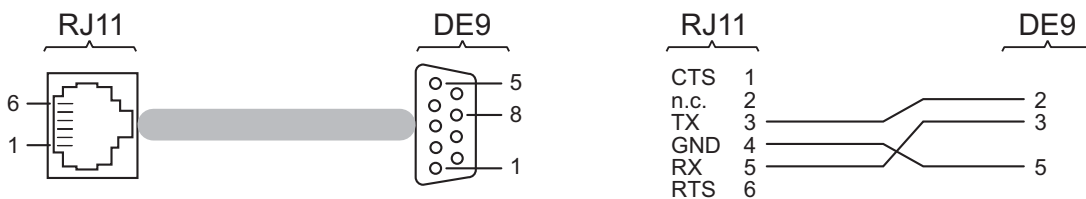

Figure 15: Pin assignment of the V.24 interface and the DE9 connector

Note: The terminal cable is available as an accessory.

2 Installation

The devices have been developed for practical application in a harsh industrial environment.

On delivery, the device is ready for operation.

Perform the following steps to install and configure the device:

- ▶ [Checking the package contents](#)
- ▶ [Installing and grounding the device](#)
- ▶ [Installing an SFP transceiver \(optional\)](#)
- ▶ [Adjust DIP switch settings](#)
- ▶ [Connecting the terminal block](#)
- ▶ [Connecting the ferrite](#)
- ▶ [Mounting the terminal block](#)
- ▶ [Operating the device](#)
- ▶ [Connecting data cables](#)
- ▶ [Filling out the inscription label](#)

2.1 Checking the package contents

Proceed as follows:

- Check whether the package includes all items named in the section [“Scope of delivery” on page 75](#).
- Check the individual parts for transport damage.

2.2 Installing and grounding the device



WARNING

FIRE HAZARD

Install the device in a fire enclosure according to EN 60950-1.

Failure to follow these instructions can result in death, serious injury, or equipment damage.

Only when using the PoE power supply unit RPS90/48V HV:



WARNING

ELECTRIC SHOCK

Install this device solely in a switch cabinet or in an operating site with restricted access, to which maintenance staff have exclusive access. Install the device at ambient temperatures greater than 113 °F (45 °C) in “restricted access locations” based on EN 60950-1 exclusively.

Failure to follow these instructions can result in death, serious injury, or equipment damage.

2.2.1 Installing the device onto the DIN rail

Verify that the device maintains the minimum clearing in order to meet the climatic conditions:

- ▶ Top and bottom device side: 3.94 in (10 cm)
- ▶ Left and right device side: 0.79 in (2 cm)

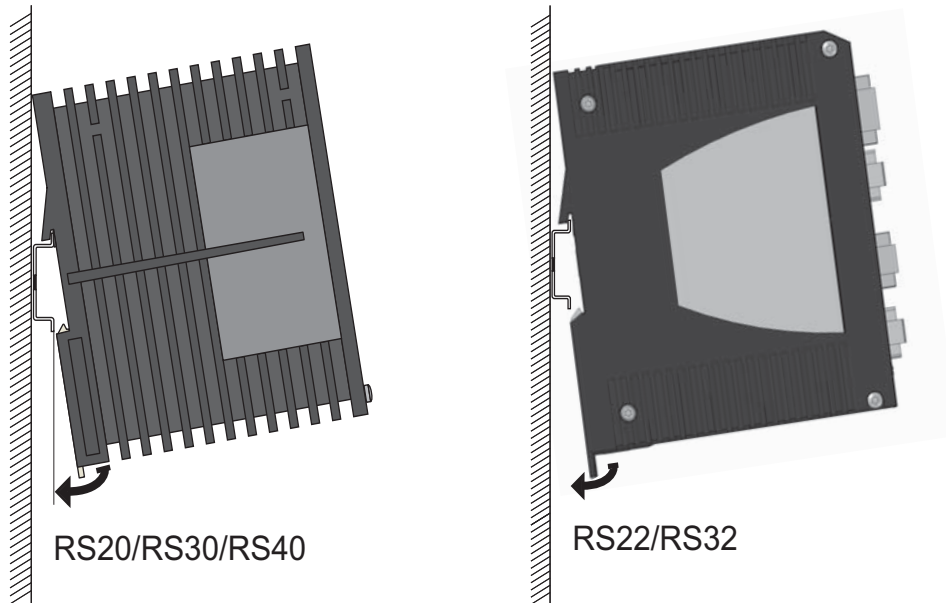

To mount the device onto a horizontally mounted 35 mm DIN rail according to DIN EN 60715, proceed as follows:

- Slide the upper snap-in guide of the device into the DIN rail.
- Pull down the locking gate using a screwdriver and press the lower part of the device against the DIN rail.
- Snap in the device by releasing the locking gate.

Note: The overall shield of a connected shielded twisted pair cable is connected to the ground connector on the front panel as a conductor.

2.2.2 DIN rail mounting on ships (RS30-0802...)

When you are mounting your RS30-0802... Open Rail device on a DIN rail on ships and in similar applications, the Open Rail Mounting Kit available as an accessory can be used to avoid excessive resonance.

- You must use the Open Rail Mounting Kit with the order number 942 007-001 when mounting your RS30-0802... device on ships. If you have very little space on your DIN rail, you can alternatively use Open Rail Mounting Kit 942 007-101 (for mounting DIN rail on DIN rail).
- Mount one mounting kit on each side of your RS30-0802... device, but at least one mounting kit on one side of the RS30-0802... device. If possible, position one side of the RS30-0802... device on a wall, or in a similarly stable way. If you are positioning multiple RS30-0802... devices side by side, mount the row of devices in the way described for a single device.
- Mount a standard DIN rail stopper on both sides beside the mounting kit.

For more information on mounting the RS30-0802... on a DIN rail on ships, see the “Open Rail Mounting Kit Mounting Instructions” manual supplied with the Open Rail Mounting Kit.

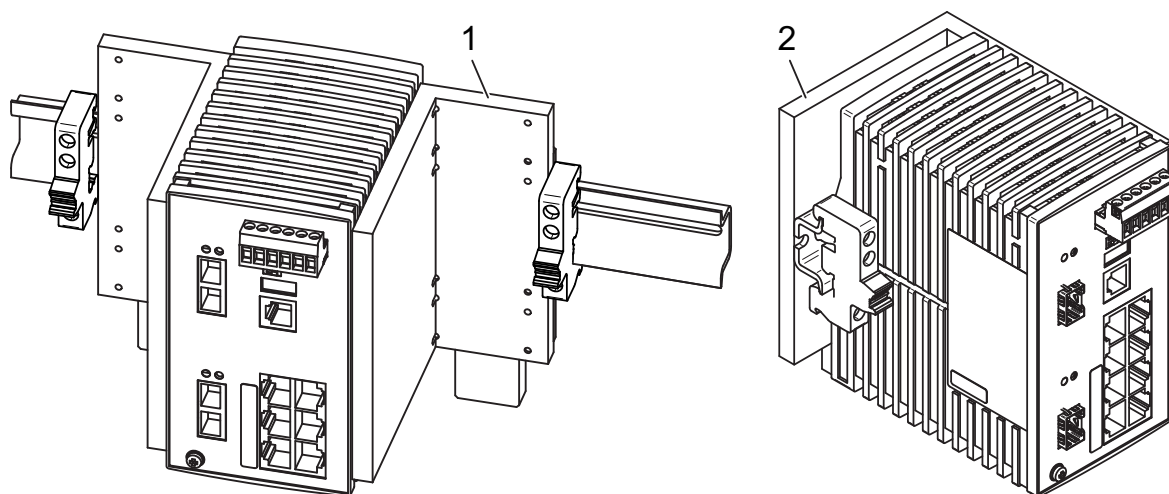

Figure 16: Mounting the RS30-0802... on ships with the Open Rail Mounting Kit
1 - Open Rail Mounting Kit 942 007-001
2 - Open Rail Mounting Kit 942 007-101

2.2.3 Mounting on a vertical flat surface

Applies to the device variants RS22 and RS32:

You have the option of attaching the device to a vertical flat surface. This requires a wall mounting plate, which you purchase as a separate accessory. See “Accessories” on page 76.

Verify that the device maintains the minimum clearing in order to meet the climatic conditions:

- ▶ Top and bottom device side: 3.94 in (10 cm)
- ▶ Left and right device side: 0.79 in (2 cm)



- Mount the device on the wall plate as shown in the illustration. Insert the upper snap-in guide of the device into the rail and press it down against the rail until it snaps into place.
- Fasten the wall plate ([see on page 76 “Accessories”](#)) on a level wall surface using four screws.

2.2.4 Grounding the device

Use a wire diameter for the ground conductor that is no smaller than the diameter of the supply voltage connection, however of at least 1.0 mm² (AWG16).

With the RS20/RS30/RS40, the front panel of the device is grounded via the separate ground screw.

With the RS22/RS32, the front panel and the metal housing of the device is grounded via the separate ground screw.

2.3 Installing an SFP transceiver (optional)

Use only Hirschmann SFP transceivers which are suitable for usage with the device.

See “Accessories” on page 76.

Proceed as follows:

- Remove the protection cap from the SFP transceiver.
- Push the transceiver with the lock closed into the slot until it latches in.

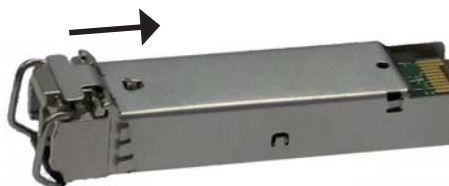

2.4 Adjust DIP switch settings

The 2-pin DIP switch on the front panel of the device gives you the following options:



Figure 17: 2-pin DIP switch

Switch RM Position	Switch Stand-by Position	Ring redundancy	Coupling switch	Ring manager	Coupling manager	Ring port	Control port	Coupling port	Software configuration
OFF	OFF	an	an	aus	aus	1 + 2			
ON	OFF	on	on	on	off	1 + 2			
OFF	ON	on	on	off	on	1 + 2	3	4	
ON	ON								SW configuration has priority over DIP switch configuration

Delivery state: both DIP switches “ON”.

- Before starting operation of the device, check whether the default settings of the DIP switch correspond to your requirements.

2.5 Connecting the terminal block

WARNING

ELECTRIC SHOCK

Connect only a supply voltage that corresponds to the type plate of your device.
Never insert sharp objects (small screwdrivers, wires, etc.) into the connection terminals for electric conductors, and do not touch the terminals. Observe the maximum values for the contact load of the signal contact.

Failure to follow these instructions can result in death, serious injury, or equipment damage.

2.5.1 RS20/RS30/RS40: supply voltage and signal contact

The supply voltage and the signal contact are connected via a 6-pin terminal block with a snap lock.

■ **Supply voltage for RS20/RS30/RS40**

The supply voltage can be connected redundantly. Both inputs are uncoupled. There is no distributed load. With redundant supply, the power supply unit with the higher output voltage supplies the device on its own. The supply voltage is electrically isolated from the housing.

See “Insulation voltage” in section “[Technical data](#)” on page 64.

You can choose between DC or AC voltage when connecting the supply voltage. You use the +24V and 0V pins to connect the AC voltage (see [figure 18](#)).

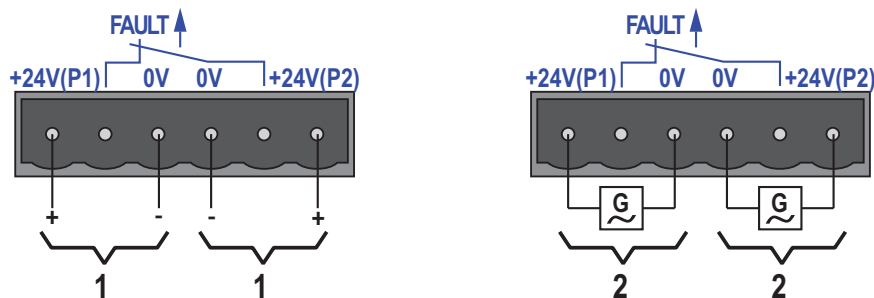

Figure 18: Connecting the supply voltage at the 6-pin terminal block
1 – DC voltage, voltage range: 9.6 V DC to 60 V DC
2 – AC voltage, voltage range: 18 V AC to 30 V AC

With a non-redundant supply of the supply voltage, the device reports the loss of a supply voltage. You can prevent this message by changing the configuration in the Management.

■ **Signal contact for RS20/RS30/RS40**

- ▶ The signal contact (“FAULT”, for pin assignment of terminal block, see [figure 18](#)) monitors the functioning of the device, thus enabling remote diagnostics. You can specify the type of function monitoring in the Management.
- ▶ You can also use the graphical user interface of the switch to switch the signal contact manually and thus control external devices.

The potential-free signal contact (relay contact, closed circuit) reports through a break in contact:

- ▶ The detected inoperability of at least one of the two voltage supplies (voltage supply 1 or 2 is below the threshold value).
- ▶ The device is not operational.
- ▶ The failure of the connection on at least one port.
The report of the link status can be masked by the Management for each port. In the delivery state, is deactivated.
- ▶ Failure of the ring redundancy reserve.
- ▶ Errors detected during the self-diagnostic test.
- ▶ Incorrect configuration of the HIPER-Ring or ring coupling.

The following condition is also reported in RM mode:

- ▶ Ring redundancy reserve is available. On delivery, there is no ring redundancy monitoring.
- Pull the terminal block off the device and connect the power supply and signal lines.

2.5.2 RS22/RS32: supply voltage and signal contact

The PoE voltage and the signal contact are connected via a 6-pin terminal block with a snap lock.

The RS22/RS32 devices are supplied with PoE voltage (48 V DC safety low voltage) via an external power supply unit.

The RS22/RS32 devices fulfill the technical data and the certifications when using the RPS90/48V LV and RPS90/48V HV power units from Hirschmann. Only use these power units, to ensure that the specifications are fulfilled.

- Make sure that the external power supply unit you use to provide the PoE voltage fulfills the following basic prerequisites:
 - ▶ Insulation requirements according to IEEE 802.3af (insulation resistance 48 V, output to “rest of the world” 2,250 V DC for 1 min.).
 - ▶ Output power < 100 W
 - ▶ Current limitation < 5 A
 - ▶ The power supply unit and the devices with PoE ports form a “limited power source” according to IEC 60950-1.
 - ▶ The external PoE power supply unit must be able to provide the power for the connected PDs (Power Devices) and for the Switch.

■ RPS90/48V LV: connecting the input voltage

With the RPS90/48V LV low-voltage PoE power unit, you connect a DC supply voltage of 24 V DC to 48 V DC at the input connection.

The supply voltage is connected via pin 1 and pin 2.

Figure	Pin	Assignment	Supply voltage range
	1	Minus terminal of the supply voltage	Low voltage input voltage: 24 V DC to 48 V DC
	2	Plus terminal of the supply voltage	

Table 12: Connecting the low-voltage supply voltage at PoE power unit RPS90/48V LV

- First connect the protective conductor to the protective conductor terminal.
- Connect the DC voltage to the 2-pin terminal block.
- Use a supply cable with a maximum length of 2 meters to the power unit.

■ RPS90/48V HV: connecting the input voltage

With the RPS90/48V HV high-voltage PoE power unit, you connect either a DC or AC supply voltage at the input connection:

- ▶ 60 V DC to 250 V DC
- ▶ 110 V AC to 230 V AC

The supply voltage is connected via pin 2 and pin 3, and the protective conductor is connected via pin 1.

Figure	Pin	Assignment	Supply voltage range
	1	Protective conductor	High voltage input voltage: 110 V AC to 230 V AC
	2	Minus terminal of the supply voltage	
	3	Plus terminal of the supply voltage	

Table 13: Connecting the high-voltage supply voltage at PoE power unit RPS90/48V HV (AC voltage)

Figure	Pin	Assignment	Supply voltage range
	1	Protective conductor	High-voltage input voltage: 60 V DC to 250 V DC
	2	Minus terminal of the supply voltage	
	3	Plus terminal of the supply voltage	
			= external fuse for supply voltages > 125 V DC

Table 14: Connecting the high-voltage supply voltage at PoE power unit RPS90/48V HV (DC voltage)

- First connect the protective conductor to the protective conductor terminal.
- Connect the supply voltage via the 3-pin terminal block. Pay attention to the +/L and -/N connections.
- If the neutral conductor or the minus terminal of the supply voltage is not grounded, install a suitable fuse in the input line.
- For supply voltages > 125 V DC:
Install a suitable external fuse in the supply voltage input line of the plus terminal.
- Use a supply cable with a maximum length of 2 meters to the power unit.

■ RS22/RS32 supply voltage

The RPS90/48V LV and RPS90/48V HV PoE power supply units provide an output voltage of typically 48 V DC for supplying the RS22-.../RS32-... devices with the PoE voltage.

Figure	Pin	Assignment	Supply voltage range
	1+2	Minus terminal of the output voltage	Output voltage (PoE voltage) range: 48 V DC to 54 V DC (default: 48 V DC)
	3+4	Plus terminal of the output voltage	

Table 15: Output voltage of RPS90/48V LV and RPS90/48V HV PoE power units

- Connect the PoE voltage to the 6-pin terminal block for the device included in the delivery.
 - Make sure the following requirements are met:
 - ▶ Supply line length < 0.5 m.

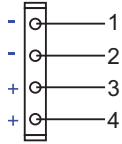
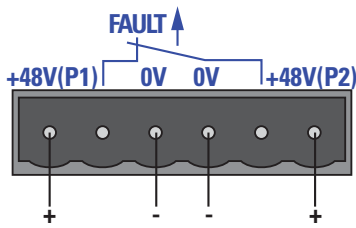

Figure 19: Connecting the PoE voltage at the 6-pin terminal block of the RS22/RS32 devices

■ RS22/RS32 signal contact

- ▶ The signal contact (“FAULT”, for pin assignment of terminal block, see [figure 19](#)) monitors the functioning of the device, thus enabling remote diagnostics. You can specify the type of function monitoring in the Management.
- ▶ You can also use the graphical user interface of the switch to switch the signal contact manually and thus control external devices.

The potential-free signal contact (relay contact, closed circuit) reports through a break in contact:

- ▶ The detected inoperability of at least one of the two voltage supplies (voltage supply 1 or 2 is below the threshold value).
- ▶ The device is not operational.
- ▶ The failure of the connection on at least one port.
 - The report of the link status can be masked by the Management for each port. In the delivery state, is deactivated.
- ▶ Failure of the ring redundancy reserve.

- ▶ Errors detected during the self-diagnostic test.
- ▶ Incorrect configuration of the HIPER-Ring or ring coupling.

The following condition is also reported in RM mode:

- ▶ Ring redundancy reserve is available. On delivery, there is no ring redundancy monitoring.
- Pull the terminal block off the device and connect the power supply and signal lines.

2.6 Mounting the terminal block

- Mount the terminal block for the voltage supply and signal contact on the front of the device using the snap lock. Verify that the snap lock latches in place.

2.7 Connecting the ferrite

Note: For PoE devices with 16 or more ports (RS22-16..., RS22-17..., RS22-24... and RS22-25...):

To adhere to EMC conformity, you connect the ferrite supplied to the voltage input via the power supply cable.

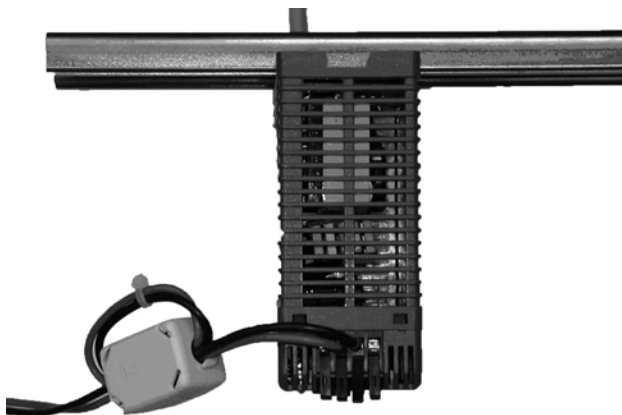

- Insert both cables of the 48V output through the ferrite twice.
- Lock the ferrite.
- Position the ferrite as close as possible to the voltage input (max. distance 19.7 inches (50 cm)).

To open the ferrite use the key supplied.

2.8 Operating the device

- By connecting the supply voltage via the terminal block, you start the operation of the device.

2.9 Connecting data cables

Note the following general recommendations for data cable connections in environments with high electrical interference levels:

- ▶ Keep the length of the data cables as short as possible.
- ▶ Use optical data cables for the data transmission between the buildings.
- ▶ When using copper cables, provide a sufficient separation between the power supply cables and the data cables. Ideally, install the cables in separate cable channels.
- ▶ Verify that power supply cables and data cables do not run parallel over longer distances, and that ideally they are installed in separate cable channels. If reducing the inductive coupling is necessary, verify that the power supply cables and data cables cross at a 90° angle.
- ▶ Use shielded cables (SF/UTP cables as per ISO/IEC 11801:2002).
- Connect the data cables according to your requirements.

For further information see [“Description of the device variants” on page 21](#).

2.10 Filling out the inscription label

The information field for the IP address helps you identify your device.

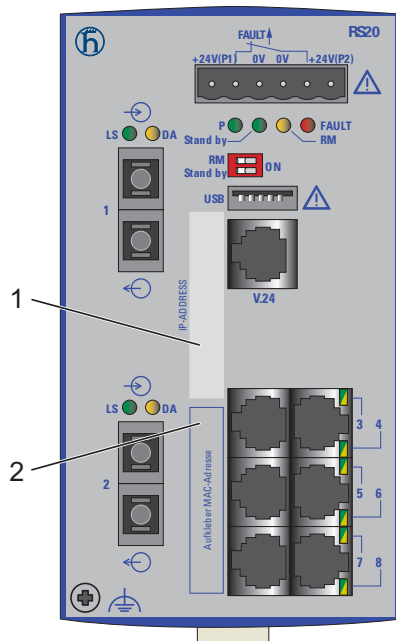

Figure 20: Label area for IP address of device
1 – IP address of device (label area)
2 – MAC address of device (label)

3 Making basic settings

WARNING

UNINTENTIONAL OPERATION IN DEVICE

Install and maintain a process that assigns a unique IP address to every device in the network.

Failure to follow these instructions can result in death, serious injury, or equipment damage.

The IP parameters must be entered when the device is installed for the first time. The device provides the following options for configuring IP addresses:

- ▶ Configuration via V.24 connection
- ▶ Configuration using the HiDiscovery protocol
- ▶ Configuration via BOOTP
- ▶ Configuration via DHCP
- ▶ Configuration via DHCP (Option 82)
- ▶ Configuration using AutoConfiguration Adapter

■ **Default settings**

- ▶ IP address: The device looks for the IP address using DHCP
- ▶ Password for management:
 - Login: user; password: public (read only)
 - Login: admin; password: private (read and write)
- ▶ V.24 data rate: 9,600 Baud
- ▶ Ring redundancy: disabled
- ▶ Ethernet ports: link status is not evaluated (signal contact)
- ▶ Optical 100 Mbit/s ports: 100 Mbit/s, full duplex
- ▶ All other ports: autonegotiation
- ▶ Ring Manager disabled (DIP switch RM and Stand-by: ON)
- ▶ Stand-by coupling disabled (DIP switch RM and stand-by: ON), Port 4 = control port, Port 3 = coupling port for redundant ring coupling
- ▶ Rapid Spanning Tree enabled

4 Monitoring the ambient air temperature

Operate the device below the specified maximum ambient air temperature exclusively.

See [“General technical data” on page 64](#).

The ambient air temperature is the temperature of the air at a distance of 2 in (5 cm) from the device. It depends on the installation conditions of the device, e.g. the distance from other devices or other objects, and the output of neighboring devices.

The temperature displayed in the CLI and the GUI is the internal temperature of the device. It is higher than the ambient air temperature. The maximum internal temperature of the device named in the technical data is a guideline that indicates to you that the maximum ambient air temperature has possibly been exceeded.

5 Maintenance and service

- ▶ When designing this device, Hirschmann largely avoided using high-wear parts. The parts subject to wear and tear are dimensioned to last longer than the lifetime of the product when it is operated normally. Operate this device according to the specifications.
- ▶ Relays are subject to natural wear. This wear depends on the frequency of the switching operations. Check the resistance of the closed relay contacts and the switching function depending on the frequency of the switching operations.
- ▶ Hirschmann is continually working on improving and developing their software. Check regularly whether there is an updated version of the software that provides you with additional benefits. You find information and software downloads on the Hirschmann product pages on the Internet (www.hirschmann.com).
- ▶ Depending on the degree of pollution in the operating environment, check at regular intervals that the ventilation slots in the device are not obstructed.

Note: You will find information about the complaints and returns procedures on the Internet under

<http://www.beldensolutions.com/en/Service/Repairs/index.phtml> .

6 Disassembly

6.1 Removing the device

WARNING

ELECTRIC SHOCK

Disconnect the grounding only after disconnecting all other cables.

Failure to follow these instructions can result in death, serious injury, or equipment damage.

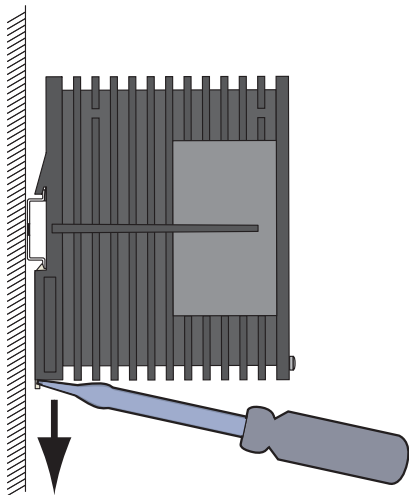

RS20/RS30/RS40

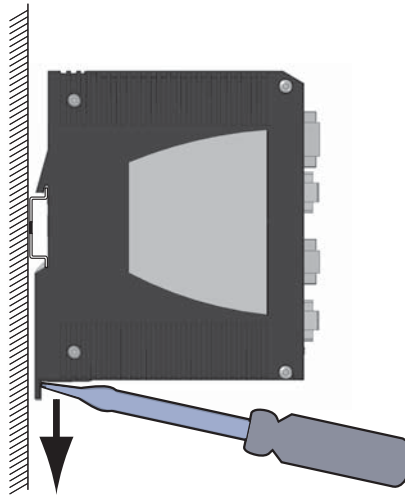

RS22/RS32

Proceed as follows:

- Disconnect the data cables.
- Disable the supply voltage.
- Disconnect the terminal blocks.
- Disconnect the grounding.
- Insert a screwdriver horizontally below the housing into the locking gate.
- Without tilting the screwdriver, pull the locking gate down and tilt the device upwards.

6.2 Removing an SFP transceiver (optional)



Proceed as follows:

- Pull the SFP transceiver out of the slot by means of the opened lock.
- Close the SFP transceiver with the protective cap.

7 Technical data

■ General technical data

Dimensions B × H × T	RS20-0400...	1.85 in. × 5.16 in. × 4.37 in. (47 mm × 131 mm × 111 mm)	
	RS20-08..., RS20-09..., RS30-0802	2.91 in. × 5.16 in. × 4.37 in. (74 mm × 131 mm × 111 mm)	
	RS20-16..., RS20-17..., RS30-1602	4.33 in. × 5.16 in. × 4.37 in. (110 mm × 131 mm × 111 mm)	
	RS20-24..., RS20-25..., RS30-2402	4.33 in. × 5.16 in. × 4.37 in. (110 mm × 131 mm × 111 mm)	
	RS40-0009CCCCS...	2.91 in. × 5.16 in. × 4.37 in. (74 mm × 131 mm × 111 mm)	
	RS40-0009CCCCE...,	4.33 in. × 5.16 in. × 4.37 in. (110 mm × 131 mm × 111 mm)	
	RS40-0009CCCCT...	4.33 in. × 5.16 in. × 4.37 in. (110 mm × 131 mm × 111 mm)	
	RS22-08..., RS22-09..., RS32-0802	3.54 in. × 5.39 in. × 4.53 in. (90 mm × 137 mm × 115 mm)	
	RS22-16..., RS22-17..., RS32-1602	4.72 in. × 5.39 in. × 4.53 in. (120 mm × 137 mm × 115 mm)	
	RS22-24..., RS22-25..., RS32-2402	4.72 in. × 5.39 in. × 4.53 in. (120 mm × 137 mm × 115 mm)	
	PoE power supply unit RPS 90/48V LV	2.36 in. × 5.39 in. × 4.53 in. (60 mm × 137 mm × 115 mm)	
	PoE power supply unit RPS 90/48V HV	2.36 in. × 5.39 in. × 4.53 in. (60 mm × 137 mm × 115 mm)	
	Weight	RS20-0400...	14.11 oz (400 g)
		RS20-08..., RS20-09..., RS30-0802	14.46 oz (410 g)
RS20-16..., RS20-17..., RS30-1602		21.16 oz (600 g)	
RS20-24..., RS20-25..., RS30-2402		20.90 oz (650 g)	
RS40-0009CCCCS...		18.70 oz (530 g)	
RS40-0009CCCCE...,		21.16 oz (600 g)	
RS40-0009CCCCT...			
RS22-08..., RS22-09..., RS32-0802		28.92 oz (820 g)	
RS22-16..., RS22-17..., RS32-1602		40.57 oz (1150 g)	
RS22-24..., RS22-25..., RS32-2402		42.33 oz (1200 g)	
PoE power supply unit RPS 90/48V LV		27.16 oz (770 g) 26.10 oz (740 g)	
PoE power supply unit RPS 90/48V HV			
Power supply RS20-..., RS30-..., RS40-...		Nominal voltage AC	24 V
		Max. voltage range AC	18 V ... 30 V (incl. max. tolerances)
	Rated voltage range DC	12 V ... 48 V	
	Max. voltage range DC	9.6 V ... 60 V (incl. max. tolerances)	
	Connection type	6-pin terminal block with snap lock	
	Power loss buffer	> 10 ms	
	Back-up fuse	Nominal rating: 3.5 A Characteristic: slow blow	
	Peak inrush current	< 14 A	

Power supply RS22-..., RS32-...	Nominal voltage AC	48 V
	Max. voltage range AC	47 V ... 52 V (incl. max. tolerances)
	Connection type	6-pin terminal block with snap lock
	Power loss buffer	> 10 ms
	Back-up fuse	Nominal rating: 3.5 A Characteristic: slow blow
	Peak inrush current	< 14 A
PoE power unit RPS90/48V HV	Nominal voltage AC	110 V ... 230 V, 50 Hz ... 60 Hz
	Voltage range AC	90 V ... 265 V, 47 Hz ... 63 Hz (incl. max. tolerances)
	Power consumption at 110 V AC	1.00 A
	Power consumption at 230 V AC	0.50 A
	Nominal voltage DC	60 - 250 V
	Voltage range DC	48 V ... 320 V (incl. max. tolerances)
	Current consumption at 60 V DC	1.70 A
	Current consumption at 250 V DC	0.39 A
	Connection type	3-pin terminal block
	Output voltage	48 V ... 54 V DC (variable, default value: 48 V DC)
	Power output	At up to +60 °C: 90 W At +60 °C to +70 °C: 60 W
	Power loss buffer	> 10 ms
	Back-up fuse	Nominal rating: 6.3 A Characteristic: slow blow
	Peak inrush current	< 15 A
PoE power unit RPS90/48V LV	Nominal voltage DC	24 V ... 48 V
	Voltage range DC	18 V ... 60 V (incl. max. tolerances)
	Current consumption at 24 V DC	4.20 A
	Current consumption at 48 V DC	2.10 A
	Connection type	2-pin terminal block
	Output voltage	48 V ... 54 V DC (variable, default value: 48 V DC)
	Power output	At up to +60 °C: 90 W At +60 °C to +70 °C: 60 W
	Power loss buffer	> 10 ms
	Back-up fuse	Nominal rating: 10 A Characteristic: slow blow
Peak inrush current	< 15 A	
Overload current protection at input	Non-replaceable fuse	
Insulation voltage between supply voltage connections and housing	800 V DC Protective elements limit the insulation voltage to 90 V DC (1 mA)	
"FAULT" signal contact	Switching current	max. 1 A, SELV
	Switching voltage	max. 60 V DC or max. 30 V AC, SELV

Environment	Storage temperature (ambient air)	Standard: -40 °F ... +158 °F (-40 °C ... +70 °C) Extended -40 °F ... +185 °F (-40 °C ... +85 °C)
	Humidity	10 % ... 95 % (non-condensing)
	Air pressure	Up to 2000 m (795 hPa), higher altitudes on request
	Minimum clearance around the device	Top and bottom device side: 3.94 in (10 cm) Left and right device side: 0.79 in (2 cm)
Operating temperature ^a	RS20/RS30/RS40	Standard: +32 °F ... +140 °F (0 °C ... +60 °C) Extended -40 °F ... +158 °F (-40 °C ... +70 °C)
	RS22-..., RS32-...	Standard: 0 °C ... +60 °C ^{b)} Extended: -40 °F ... +140 °F (-40 °C to +60 °C) ^{c)}
	RS40-...B... (ATEX/IECEX) Standard (S)	Temperature code T4: +32 °F ... +140 °F (0 °C ... +60 °C)
	RS40-...B... (ATEX/IECEX) Extended (E and T)	Temperature code T3: -40 °F ... +158 °F (-40 °C ... +70 °C) Temperature code T4: -40 °F ... +140 °F (-40 °C ... +60 °C)
	RPS90/48V HV	-40 °F ... +158 °F (-40 °C ... +70 °C) Cold start at temperatures > -30 °C
	RPS90/48V LV	-40 °F ... +158 °F (-40 °C ... +70 °C) Cold start at temperatures > -30 °C at an input voltage ≥ 21.6 V DC
Pollution degree	2	
Protection classes	Laser protection	Class 1 in compliance with IEC 60825-1
	Degree of protection	IP20

- a. Exclusively use SFP modules with the “EEC” extension at temperatures > 60 °C and < 0 °C.
- b. With a UL-508, ATEX/IECEX, or ISA 12.12.01 approval, the maximum operating temperature for the standard ‘S’ temperature range for PoE-capable devices (RS22-..., RS32-...) is +122 °F (+50 °C).
- c. With a UL-508, ATEX/IECEX, or ISA 12.12.01 approval, the maximum operating temperature for the extended ‘E’ and ‘T’ temperature range for PoE-capable devices (RS22-..., RS32-...) is +122 °F (+50 °C).

■ Dimension drawings

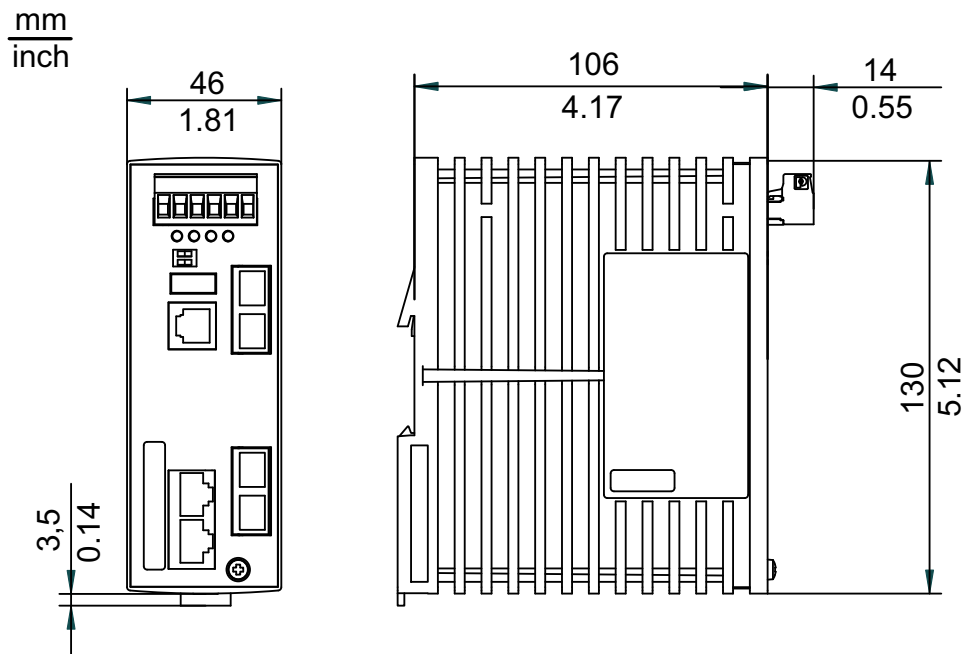

Figure 21: Dimensions of device variants RS20-04...
with operating temperature characteristic value S, T and E

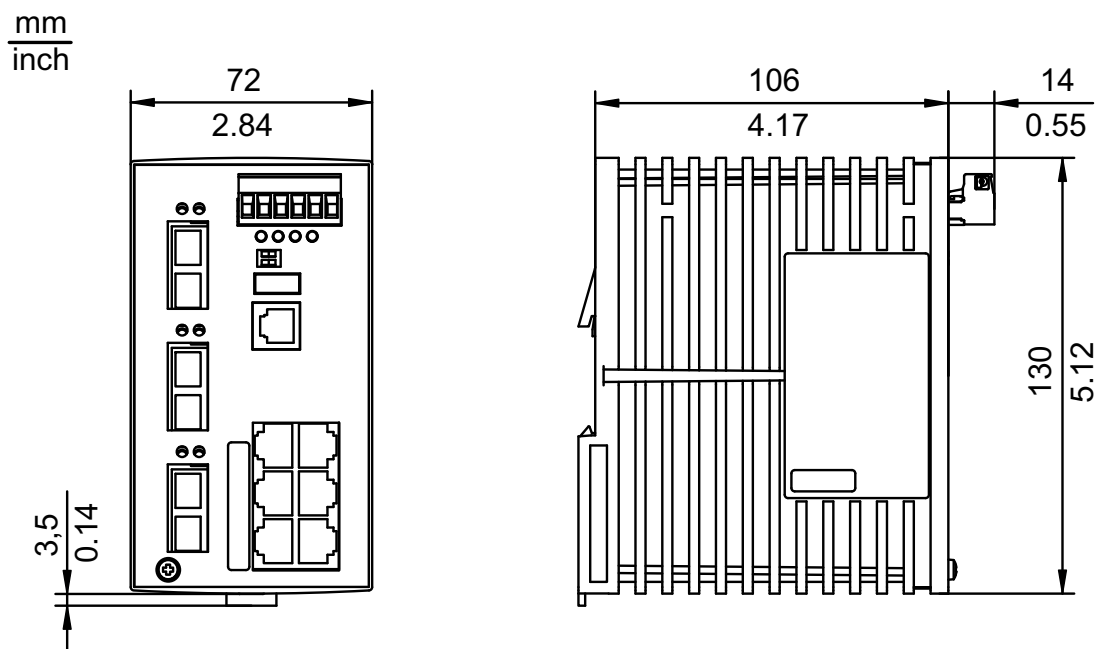

Figure 22: Dimensions of device variants
- RS20-08... and RS20-09... with operating temperature
characteristic value S, T and E
- RS30-08... with operating temperature characteristic value S, T and E
- RS40-09... with operating temperature characteristic value S

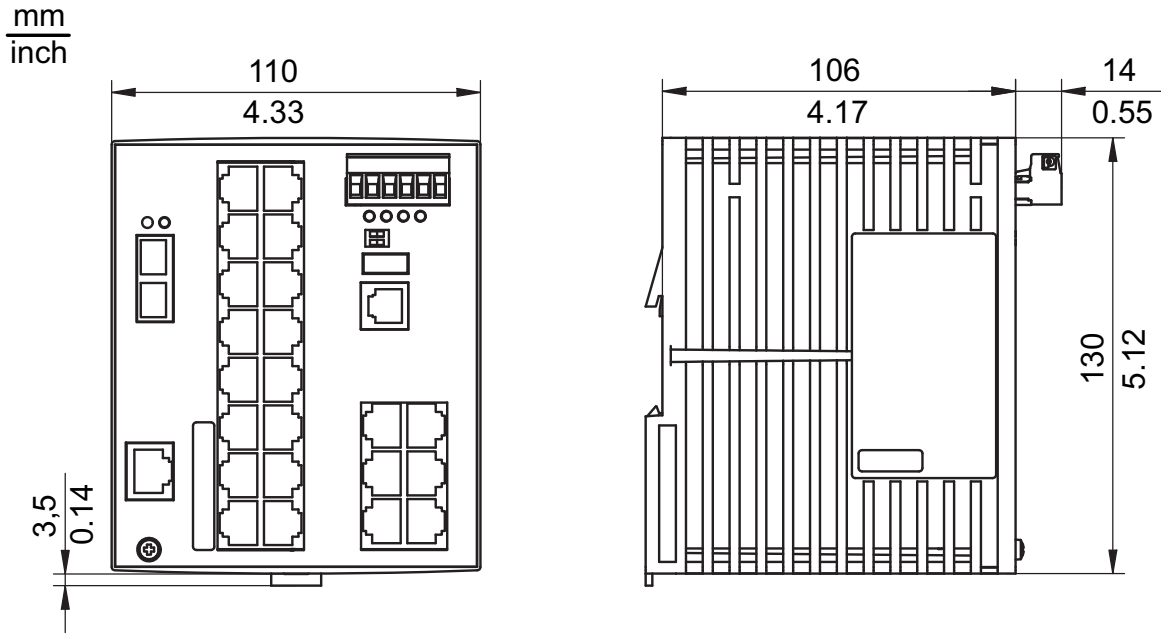

Figure 23: Dimensions of device variants

- RS20-16... , RS20-17... and RS20-24... with operating temperature characteristic value S, T and E
- RS30-16... and RS30-24... with operating temperature characteristic value S, T and E
- RS40-09... with operating temperature characteristic value T and E

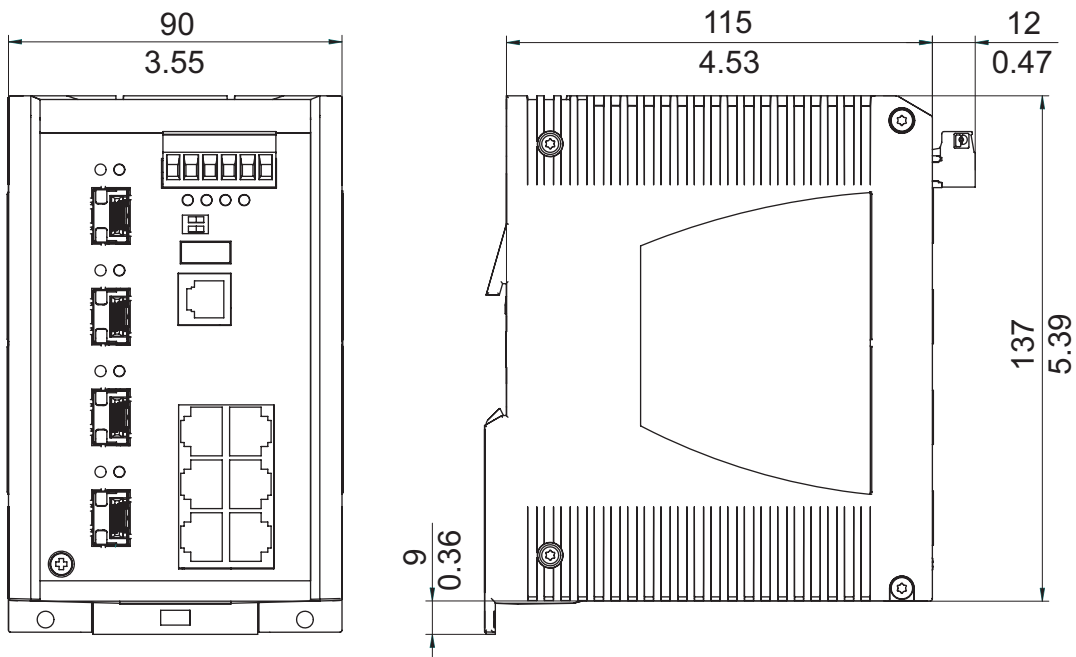

Figure 24: Dimensions of device variants RS22.../RS32... with 8 to 10 ports with operating temperature characteristic value S, T and E

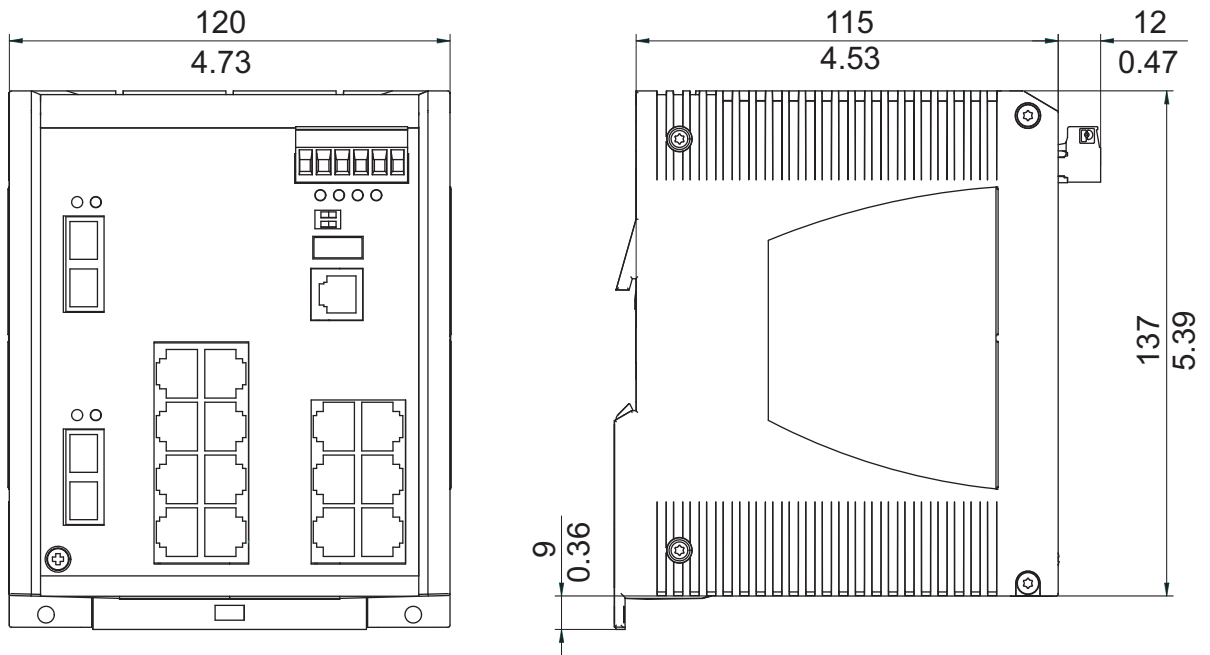

Figure 25: Dimensions of device variants RS22.../RS32... with 16 to 26 ports with operating temperature characteristic value S, T and E

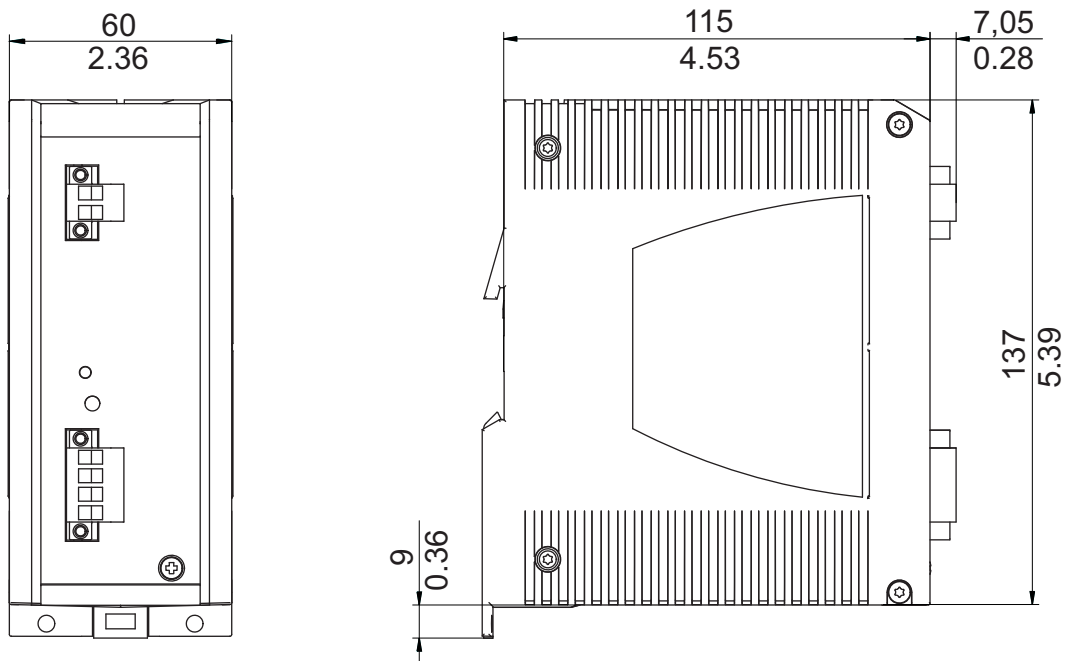

Figure 26: Dimensions of RPS90/48V LV and RPS90/48V HV PoE power units

■ EMC and immunity

EMC compliance – IEC/EN 61000-6-2:2005 EMI TYPE tests, test acc. to:		A ^{a)}	B ^{a)}	H ^{a)}
IEC/EN 61000-4-2	Electrostatic discharge			
	Contact discharge	4 kV	8 kV	8 kV
	Air discharge	8 kV	15 kV	15 kV
IEC/EN 61000-4-3	Electromagnetic field			
	80 MHz ... 3000 MHz	10 V/m	20 V/m	20 V/m
IEC/EN 61000-4-4	Fast transients (burst)			
	Power line	2 kV	4 kV	4 kV
	Data line	1 kV	4 kV	4 kV
IEC/EN 61000-4-5	Voltage surges			
	Power line, line / line	0.5 kV	1 kV	1 kV
	Power line, line / ground	1 kV	2 kV	2 kV
	Data line	1 kV	4 kV	4 kV
IEC/EN 61000-4-6	Conducted disturbances			
	10 kHz - 150 kHz	3 V	3 V	3 V
	150 kHz ... 80 MHz	10 V	10 V	10 V
EN 61000-4-9	Pulse magnetic fields	—	300 A/m	300 A/m
EMC interference emission		A ^{a)}	B ^{a)}	H ^{a)}
EN 55022	Class A	Yes	Yes	Yes
FCC 47 CFR Part 15	Class A	Yes	Yes	Yes
German Lloyd	Classification + Construction Guidelines VI-7-3 Part 1 Ed.2001	—	Yes	Yes
Stability		A ^{a)}	B ^{a)}	H ^{a)}
Vibration	IEC 60068-2-6 Test FC test level according to IEC 61131-2	Yes	Yes	Yes
	Germanischer Lloyd Guidelines for the Performance of Type Tests Part 1	—	Yes	Yes
	IEC 60870-2-2 table 3 normal installation according to EN 61850-3	—	Yes	Yes
Shock	IEC 60068-2-27 Test Ea test level according to IEC 61131-2	Yes	Yes	Yes
	IEC 60870-2-2 table 3 normal installation according to EN 61850-3	—	Yes	Yes

a.Product code A: Approval = CE, UL

Product code B: Approval = CE, UL, GL, railway (along track), Sub Station, ATEX/IECEx

Produktcode H: Zulassung = CE, UL, GL, Bahn (along track), Sub Station

(See “Combination options of the device variants RS20/RS30/RS22/RS32” on page 23.

See “Combination options for the RS40 device variants” on page 26.)

■ Network range

Note: The line lengths specified for the transceivers apply for the respective fiber data (fiber attenuation and BLP/dispersion).

Product code M-SFP-...	Wave length	Fiber	System attenuation	Example for F/O line length ^a	Fiber attenuation	BLP ^b /dispersion
-SX/LC...	MM 850 nm	50/125 μm	0-7.5 dB	0-550 m	3.0 dB/km	400 MHz×km
-SX/LC...	MM 850 nm	62.5/125 μm	0-7.5 dB	0-275 m	3.2 dB/km	200 MHz×km
-MX/LC EEC	MM 1310 nm	50/125 μm	0-12 dB	0-1.5 km	1.0 dB/km	800 MHz×km
-MX/LC EEC	MM 1310 nm	62.5/125 μm	0-12 dB	0-500 m	1.0 dB/km	500 MHz×km
-LX/LC...	MM 1310 nm ^c	50/125 μm	0-10.5 dB	0-550 m	1.0 dB/km	800 MHz×km
-LX/LC...	MM 1310 nm ^c	62.5/125 μm	0-10.5 dB	0-550 m	1.0 dB/km	500 MHz×km
-LX/LC...	SM 1310 nm	9/125 μm	0-10.5 dB	0-20 km ^d	0.4 dB/km	3.5 ps/(nm×km)
- LX+/LC...	SM 1310 nm	9/125 μm	5-20 dB	14-42 km	0.4 dB/km	3.5 ps/(nm×km)
-LH/LC...	LH 1550 nm	9/125 μm	5-22 dB	23-80 km	0.25 dB/km	19 ps/(nm×km)
-LH+/LC	LH 1550 nm	9/125 μm	15-30 dB	71-108 km	0.25 dB/km	19 ps/(nm×km)
-LH+/LC	LH 1550 nm	9/125 μm	15-30 dB	71-128 km	0.21 dB/km (typically)	19 ps/(nm×km)

Table 16: Fiber port 1000BASE-FX (SFP fiber optic Gigabit Ethernet Transceiver)

- including 3 dB system reserve when compliance with the fiber data is observed
- Using the bandwidth length product is inappropriate for expansion calculations.
- With F/O adapter compliant with IEEE 802.3-2002 clause 38 (single-mode fiber offset-launch mode conditioning patch cord)
- Including 2.5 dB system reserve when compliance with the fiber data is observed

Product code M-SFP- BIDI...	Wave length TX	Wave length RX	Fiber	System attenuation	Example for F/O line length ^a	Fiber attenuation	Dispersion
Type A LX/LC EEC	SM 1310 nm	1550 nm	9/125 μm	0-11 dB	0-20 km	0.4 dB/km	3.5 ps/(nm×km)
Type B LX/LC EEC	SM 1550 nm	1310 nm	9/125 μm	0-11 dB	0-20 km	0.25 dB/km	19 ps/(nm×km)
Type A LH/LC EEC	LH 1490 nm	1590 nm	9/125 μm	5-24 dB	23-80 km	0.25 dB/km	19 ps/(nm×km)
Type B LH/LC EEC	LH 1590 nm	1490 nm	9/125 μm	5-24 dB	23-80 km	0.25 dB/km	19 ps/(nm×km)

Table 17: F/O port (bidirectional Gigabit Ethernet SFP Transceiver)

- including 3 dB system reserve when compliance with the fiber data is observed

Product code M-FAST-SFP-...	Wave length	Fiber	System attenuation	Example for F/O line length ^a	Fiber attenuation	BLP/dispersion
-MM/LC...	MM	1310 nm	50/125 μm	0-8 dB	0-5 km	1.0 dB/km 800 MHz×km
-MM/LC...	MM	1310 nm	62.5/125 μm	0-11 dB	0-4 km	1.0 dB/km 500 MHz×km
-SM/LC...	SM	1310 nm	9/125 μm	0-13 dB	0-25 km	0.4 dB/km 3.5 ps/(nm×km)
-SM+/LC...	SM	1310 nm	9/125 μm	10-29 dB	25-65 km	0.4 dB/km 3.5 ps/(nm×km)
-LH/LC...	SM	1550 nm	9/125 μm	10-29 dB	47-104 km	0.25 dB/km 19 ps/(nm×km)
-LH/LC...	SM	1550 nm	9/125 μm	10-29 dB	55-140 km	0.18 dB/km ^b 18 ps/(nm×km)

Table 18: Fiber port 100BASE-FX (SFP fiber optic Fast Ethernet Transceiver)

- a. including 3 dB system reserve when compliance with the fiber data is observed
- b. with ultra-low-loss optical fiber

Product code	Wave length	Fiber	System attenuation	Example for F/O line length ^a	Fiber attenuation	BLP/dispersion
-M2, -MM	MM	1300 nm	50/125 μm	0-8 dB	0-5 km	1.0 dB/km 800 MHz×km
-M2, -MM	MM	1300 nm	62.5/125 μm	0-11 dB	0-4 km	1.0 dB/km 500 MHz×km
-M4, -NN	SM	1300 nm	62.5/125 μm	0-11 dB	0-4 km	1.0 dB/km 500 MHz×km
-S2, -VV	SM	1300 nm	9/125 μm	0-16 dB	0-30 km	0.4 dB/km 3.5 ps/(nm×km)
-S4, -UU	SM	1300 nm	9/125 μm	0-16 dB	0-30 km	0.4 dB/km 3.5 ps/(nm×km)
-E2, EE	SM+	1300 nm	9/125 μm	7-29 dB	20-65 km	0.4 dB/km 3.5 ps/(nm×km)
-L2, -LL	LH	1550 nm	9/125 μm	7-29 dB	24-86 km	0.3 dB/km 19 ps/(nm×km)
-G2, -GG	LH+	1550 nm	9/125 μm	14-47 dB	67-176 km	0.25 dB/km 19 ps/(nm×km)

Table 19: F/O port 100BASE-FX

- a. including 3 dB system reserve when compliance with the fiber data is observed

MM = Multimode, SM = Singlemode, LH = Singlemode Longhaul

10/100/1000 Mbit/s twisted pair port

Length of a twisted pair segment max. 109 yards (100 m) (for Cat5e cable)

■ Power consumption/power output

Device name	Device model	Maximum power consumption	Power output
2 uplink ports:			
RS20-0400...	2xTX port	5.3 W	18.1 Btu (IT)/h
RS20-0400...	1xFX port, 1xTX port	6.5 W	22.2 Btu (IT)/h
RS20-0400...	2xFX port	7.7 W	26.3 Btu (IT)/h
RS20-0800...	RS22-0800... 2xTX port	5.3 W	18.1 Btu (IT)/h
RS20-0800...	RS22-0800... 1xFX port, 1xTX port	6.5 W	22.2 Btu (IT)/h
RS20-0800...	RS22-0800... 2xFX port	7.7 W	26.3 Btu (IT)/h
RS20-1600...	RS22-1600... 2xTX port	9.4 W	32.1 Btu (IT)/h
RS20-1600...	RS22-1600... 1xFX port, 1xTX port	10.6 W	36.2 Btu (IT)/h
RS20-1600...	RS22-1600... 2xFX port	11.8 W	40.3 Btu (IT)/h
RS20-2400-...	RS22-2400-... 2xTX port	12.1 W	41.3 Btu (IT)/h
RS20-2400-...	RS22-2400-... 1xFX port, 1xTX port	13.3 W	45.4 Btu (IT)/h
RS20-2400-...	RS22-2400-... 2xFX port	14.5 W	52.9 Btu (IT)/h
RS30-0802-...	RS32-0802-... 2xTX port	8.9 W	30.4 Btu (IT)/h
RS30-0802-...	RS32-0802-... 1xFX port, 1xTX port	8.6 W	29.4 Btu (IT)/h
RS30-0802-...	RS32-0802-... 2xFX port	8.3 W	28.4 Btu (IT)/h
RS30-1602-...	RS32-1602-... 2xTX port	13.0 W	44.4 Btu (IT)/h
RS30-1602-...	RS32-1602-... 1xFX port, 1xTX port	12.7 W	43.4 Btu (IT)/h
RS30-1602-...	RS32-1602-... 2xFX port	12.4 W	42.4 Btu (IT)/h
RS30-2402-...	RS32-2402-... 2xTX port	15.7 W	53.6 Btu (IT)/h
RS30-2402-...	RS32-2402-... 1xFX port, 1xTX port	15.4 W	52.6 Btu (IT)/h
RS30-2402-...	RS32-2402-... 2xFX port	15.1 W	51.6 Btu (IT)/h
3 uplink ports:			
RS20-0900-...	RS22-0900-... 3xFX port	9.6 W	32.8 Btu (IT)/h
RS20-1700-...	RS22-1700-... 3xFX port	13.7 W	46.7 Btu (IT)/h
RS20-2500-...	RS22-2500-... 3xFX port	16.4 W	56.0 Btu (IT)/h
4 uplink ports:			
RS30-0802-...	RS32-0802-... 4xFX port	12.7 W	43.3 Btu (IT)/h
RS30-1602-...	RS32-1602-... 4xFX port	16.8 W	57.3 Btu (IT)/h
RS30-2402-...	RS32-2402-... 4xFX port	19.5 W	66.5 Btu (IT)/h
RS40-...	4xFX port	20.0 W	68.2 Btu (IT)/h

Table 20: Power consumption/power output RS20/RS30/RS40 and RS22/RS32 without PDs (powered devices)

Device name	Device model	Maximum power consumption	Power output
2 uplink ports:			
RS22-0800...	2xTX port	70.9 W	31.8 Btu (IT)/h
RS22-0800...	1xFX port, 1xTX port	72.1 W	35.9 Btu (IT)/h

Table 21: Power consumption/power output RS22/RS32 with 4 x Class0 PD (powered device)

Device name	Device model	Maximum power consumption	Power output
RS22-0800...	2xFX port	73.3 W	40.0 Btu (IT)/h
RS22-1600...	2xTX port	75.0 W	45.8 Btu (IT)/h
RS22-1600...	1xFX port, 1xTX port	76.2 W	49.9 Btu (IT)/h
RS22-1600...	2xFX port	77.4 W	54.0 Btu (IT)/h
RS22-2400-...	2xTX port	77.7 W	55.0 Btu (IT)/h
RS22-2400-...	1xFX port, 1xTX port	78.9 W	59.1 Btu (IT)/h
RS22-2400-...	2xFX port	80.1 W	66.6 Btu (IT)/h
RS32-0802-...	2xTX port	74.5 W	44.1 Btu (IT)/h
RS32-0802-...	1xFX port, 1xTX port	74.2 W	43.1 Btu (IT)/h
RS32-0802-...	2xFX port	73.9 W	42.1 Btu (IT)/h
RS32-1602-...	2xTX port	78.6 W	58.1 Btu (IT)/h
RS32-1602-...	1xFX port, 1xTX port	78.3 W	57.1 Btu (IT)/h
RS32-1602-...	2xFX port	78.0 W	56.1 Btu (IT)/h
RS32-2402-...	2xTX port	81.3 W	67.3 Btu (IT)/h
RS32-2402-...	1xFX port, 1xTX port	81.0 W	66.3 Btu (IT)/h
RS32-2402-...	2xFX port	80.7 W	65.3 Btu (IT)/h
3 uplink ports:			
RS22-0900-...	3xFX port	75.2 W	46.5 Btu (IT)/h
RS22-1700-...	3xFX port	79.3 W	60.4 Btu (IT)/h
RS22-2500-...	3xFX port	82.0 W	69.7 Btu (IT)/h
4 uplink ports:			
RS32-0802-...	4xFX port	78.3 W	57.0 Btu (IT)/h
RS32-1602-...	4xFX port	82.4 W	71.0 Btu (IT)/h
RS32-2402-...	4xFX port	85.1 W	80.2 Btu (IT)/h

Table 21: Power consumption/power output RS22/RS32 with 4 x Class0 PD (powered device)

■ Scope of delivery

Device	Scope of delivery
RS20-..., RS30-..., RS40-..., RS22-... or RS32-...	Device Terminal block for supply voltage and signal contact General safety instructions
RS22-16..., RS22-17..., RS22-24..., RS22-25...	Additionally: ferrite with key

■ Order numbers/product description

The order numbers correspond to the product codes of the devices.

[See “Combination options of the device variants](#)

[RS20/RS30/RS22/RS32” on page 23.](#)

[See “Combination options for the RS40 device variants” on page 26.](#)

■ Accessories

Note that products recommended as accessories may have different characteristics to those of the device, which may limit the application range of the overall system. For example, if you add an accessory with IP20 to a device with IP65, the IP of the overall system is reduced to IP20.

Gigabit Ethernet SFP transceiver	Order number
M-SFP-TX/RJ45	943 977-001
M-SFP-TX/RJ45 EEC	942 161-001

The following operating conditions apply to twisted pair transceivers:

- ▶ Usable with:
 - HiOS as of software version 03.0.00
 - Classic Switch software, as of software version 04.1.00.
 - HiSecOS as of software version 01.2.00
- Do not use with the following devices:
 - SPIDER II- MSP/MSM
 - EES
- ▶ Longer RSTP switching times and link loss detection times compared to twisted pair ports provided by the device directly.
- ▶ Not applicable for combo and Fast Ethernet ports.
- ▶ Only support of the autonegotiation mode including autocrossing.

M-SFP-SX/LC	943 014-001
M-SFP-SX/LC EEC	943 896-001
M-SFP-MX/LC EEC	942 108-001
M-SFP-LX/LC	943 015-001
M-SFP-LX/LC EEC	943 897-001
M-SFP-LX+/LC	942 023-001
M-SFP-LX+/LC EEC	942 024-001
M-SFP-LH/LC	943 042-001
M-SFP-LH/LC EEC	943 898-001
M-SFP-LH+/LC	943 049-001
M-SFP-LH+/LC EEC	942 119-001
SFP-GIG-LX/LC ^a	942 196-001
SFP-GIG-LX/LC EEC ^a	942 196-002

a. Further information on certifications can be found on the Internet at the Hirschmann product pages (www.hirschmann.com).

Bidirectional Gigabit Ethernet SFP transceiver	Order number
M-SFP-BIDI Type A LX/LC EEC	943 974-001
M-SFP-BIDI Type B LX/LC EEC	943 974-002
M-SFP-BIDI Type A LH/LC EEC	943 975-001
M-SFP-BIDI Type B LH/LC EEC	943 975-002
M-SFP-BIDI Bundle LX/LC EEC (type A + B)	943 974-101
M-SFP-BIDI Bundle LH/LC EEC (type A + B)	943 975-101

Fast Ethernet SFP transceiver	Order number
M-FAST SFP-TX/RJ45	942 098-001
M-FAST SFP-TX/RJ45 EEC	942 098-002

The following operating conditions apply to twisted pair transceivers:

- ▶ Usable with:
 - HiOS as of software version 03.0.00
 - for PRP ports on RSP devices, as of software version 02.0.01
 - for PRP ports on EES devices, as of software version 02.0.02
 - Classic switch software as of software version 08.0.00
 - HiSecOS as of software version 01.2.00
- ▶ Longer RSTP switching times and link loss detection times compared to twisted pair ports provided by the device directly.
- ▶ Not applicable for combo ports.
- ▶ Not applicable for ports which support only Gigabit Ethernet.
- ▶ To set autocrossing manually is currently not possible.

M-FAST SFP-MM/LC	943 865-001
M-FAST SFP-MM/LC EEC	943 945-001
M-FAST SFP-SM/LC	943 866-001
M-FAST SFP-SM/LC EEC	943 946-001
M-FAST SFP-SM+/LC	943 867-001
M-FAST SFP-SM+/LC EEC	943 947-501
M-FAST SFP-LH/LC	943 868-001
M-FAST SFP-LH/LC EEC	943 948-001
SFP-FAST-MM/LC ^a	942 194-001
SFP-FAST-MM/LC EEC ^a	942 194-002
SFP-FAST-SM/LC ^a	942 195-001
SFP-FAST-SM/LC EEC ^a	942 195-002

a. Further information on certifications can be found on the Internet at the Hirschmann product pages (www.hirschmann.com).

Special accessories for the device variants RS22/RS32	Order number
Wall mounting plate in DIN rail design, width 4.72 in. (120 mm)	943 971-001
Wall mounting plate for DIN rail mounting, width 3.54 in. (90 mm)	943 971-002
RPS 90/48V HV (high-voltage) PoE power unit	943 979-001
RPS 90/48V HV (high-voltage) PoE power unit with conformal coating	943 979-101
RPS 90/48V LV (low-voltage) PoE power unit	943 980-001
RPS 90/48V LV (low-voltage) PoE power unit with conformal coating	943 980-101

Other accessories	Order number
AutoConfiguration Adapter ACA21-USB (EEC)	943 271-003
Terminal cable	943 301-001
6-pin terminal block (50 pcs.)	943 845-006
Rail Power Supply RPS 30	943 662-003
Rail Power Supply RPS 80 EEC	943 662-080
Rail Power Supply RPS 120 EEC (CC)	943 662-121
Industrial HiVision Network Management Software	943 156-xxx
OPC server software HiOPC	943 055-001

■ Underlying technical standards

Name	
CAN/CSA C22.2 No. 213	Non-incendive Electrical Equipment for Use in Class I, Division 2 Hazardous Locations.
EN 50121-4	Railway applications - EMC - emitted interference and interference immunity for signal and telecommunication systems
EN 55022	Information technology equipment – Radio disturbance characteristics – Limits and methods of measurement
IEC/EN 60079-15	Explosive atmospheres – Part 15: Equipment protection by type of protection “n”
EN 60950-1	Information technology equipment – Safety – Part 1: General requirements
EN 61000-6-2	Electromagnetic compatibility (EMC) – Part 6-2: Generic standards – Immunity for industrial environments
EN 61131-2	Programmable controllers – Part 2: Equipment requirements and tests
FCC 47 CFR Part 15	Code of Federal Regulations
Germanischer Lloyd	Rules for Classification and Construction VI-7-2 – GL
IEC/EN 61850-3	Communication networks and systems in substations – Part 3: General requirements
IEEE 802.1D	Switching, GARP, GMRP, Spanning Tree
IEEE 802.1D	Media access control (MAC) bridges (includes IEEE 802.1p Priority and Dynamic Multicast Filtering, GARP, GMRP)
IEEE 802.1Q	Virtual LANs (VLANs, MRP, Spanning Tree)
IEEE 802.1Q	Virtual Bridged Local Area Networks (VLAN Tagging, GVRP)
IEEE 802.1w	Rapid Reconfiguration
IEEE 802.3	Ethernet
IEEE 1613	IEEE Standard Environmental and Testing Requirements for Communication Networking Devices in Electric Power Substations
Korean Register of Shipping	Rules for the Classification of Steel Ships – KR
UL 508	Safety for Industrial Control Equipment

Table 22: List of the technical standards

The device has an approval based on a specific standard only if the approval indicator appears on the device casing.

If your device has a shipping approval according to Germanischer Lloyd, you find the approval mark printed on the device label. You will find out whether your device has other shipping approvals on the Hirschmann website under www.hirschmann.com in the product information.

The device generally fulfills the technical standards named in their current versions.

A Further Support

■ Technical Questions

For technical questions, please contact any Hirschmann dealer in your area or Hirschmann directly.

You will find the addresses of our partners on the Internet at <http://www.hirschmann.com>.

A list of local telephone numbers and email addresses for technical support directly from Hirschmann is available at <https://hirschmann-support.belden.eu.com>.

This site also includes a free of charge knowledge base and a software download section.

■ Hirschmann Competence Center

The Hirschmann Competence Center is ahead of its competitors:

- ▶ Consulting incorporates comprehensive technical advice, from system evaluation through network planning to project planning.
- ▶ Training offers you an introduction to the basics, product briefing and user training with certification.

The current technology and product training courses can be found at <http://www.hicomcenter.com>

- ▶ Support ranges from the first installation through the standby service to maintenance concepts.

With the Hirschmann Competence Center, you have decided against making any compromises. Our client-customized package leaves you free to choose the service components you want to use.

Internet:

<http://www.hicomcenter.com>



HIRSCHMANN

A **BELDEN** BRAND