

# LED EUHB-240W1050



LED High Bay Light / Glass + Aluminum Housing

## Product Description

**LED EUHB-240W1050** uses big size chip SMD 2835 technology to achieve the highest luminous efficiency, which provide 140-150 lumens per watt superior brightness, up to 80% energy savings. Equip with the dimming capacity allows you to adjust the brightness over your space and save energy with the standard 1-10V dimmer. Moreover, the optional microwave motion sensor makes this light is intelligent and further energy saving. Enjoy features such as: Energy Efficient, dimming options, Wet Rated, and IP65 Protection.



**Estimated Energy Cost:** \$28.90 per year

\*Note: Design, features and specifications subject to change without notice. Some features may not be available on all models. For more information please visit: [www.eurilighting.com](http://www.eurilighting.com) or call 1-310-787-1100

\*Operating temperature (-40°F to 122°F) / Storage temperature (-40°F to 176°F)

## Specifications

Input Power	Input Voltage	Lumen Output	Beam Angle	Center Beam	CCT
240 W	100-277 V	36000 lm	110°	N/A	5000 K
CRI	Luminous Efficacy	Power Factor	Input Current	Base/Cap	Lamp Lifespan
80	150 lm/W	0.9	2.6 A	N/A	50,000 Hrs.

### Product Features



Energy Efficient



0-10V Dimmable



Wet Rated



IP65 Protection

### Product Dimensions

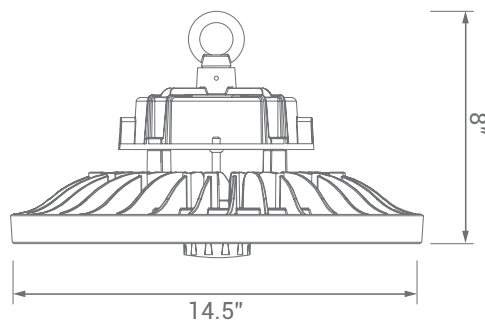

### Product Photometric Data

